

SPECIFICATION SHEET

COLLECTION: CAMEO

PRODUCT CODE: CAM-200M/CC-LP-MB

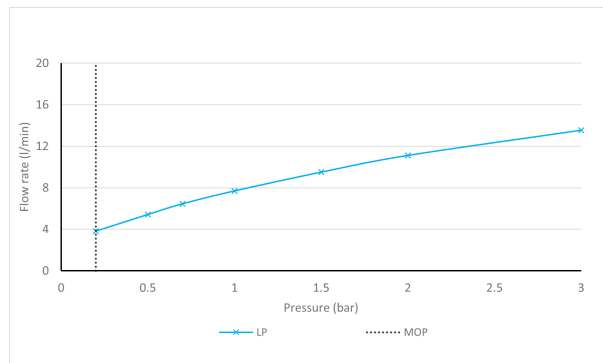

The flow rate displayed is calculated using ideal system conditions. This result should only be taken as an indication as the flow rate may vary depending on the specific in-situ configuration.

TAP TYPE

Basin Mixer

FINISH

Matt Black

COLLECTION NAME

Cameo

GUARANTEE

10 Year Guarantee

PLUMBING SYSTEM SUITABILITY

Gravity System

MINIMUM OPERATING PRESSURE

0.2 Bar LP

MAXIMUM OPERATING PRESSURE

5.0 Bar HP

HANDLES

Single Lever

MOUNTING

Deck Mounted

tel: 01934 744466
email: sales@vado.com
www.vado.com

WHERE INSPIRATION FLOWS
TAPS | SHOWERS | FURNITURE



SPECIFICATION SHEET

COLLECTION: CAMEO

PRODUCT CODE: CAM-200M/CC-LP-MB

WASTE

Universal Basin Waste

RECOMMENDED FLOW REGULATOR

5 l/min Flow Regulator

WITH ECOTURN COLD START TECHNOLOGY

No

WITH WATER FLOW STRAIGHTENER

Yes

WITH WATER FLOW AERATOR

No

CONNECTIONS / FITTINGS

2 x 1/2" 450mm flexipipe connection

DECK HOLE DRILL DIAMETER

35mm

SPARE PARTS

ceramic cartridge C-002-N25

STYLE

Square

TECHNICAL DRAWING

COLLECTION: CAMEO

PRODUCT CODE: CAM-200M/CC-LP-MB

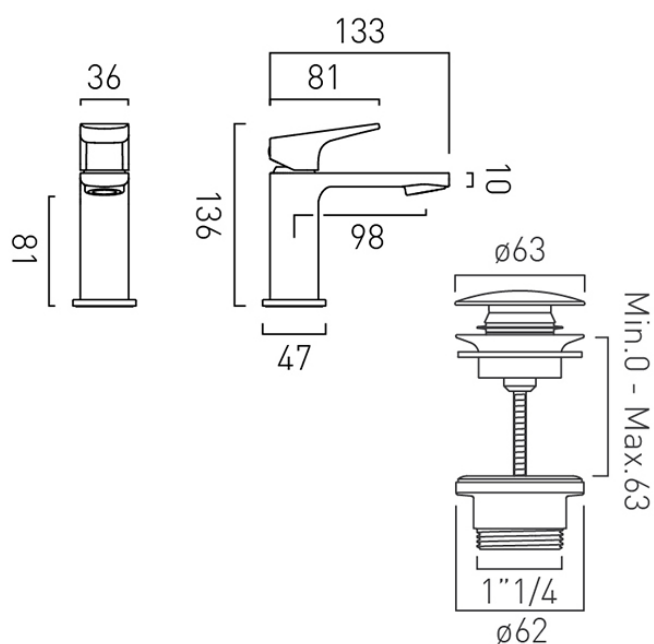

tel: 01934 744466
email: sales@vado.com
www.vado.com

WHERE INSPIRATION FLOWS
TAPS | SHOWERS | FURNITURE

