SPECIFICATION SHEET

COLLECTION: AXBRIDGE

PRODUCT CODE: BC-AXB-149/RRK-BN



DESCRIPTION:

Axbridge
2 Outlet Exposed Shower Column
wall mounted
with water flow straightener
traditional 200mm shower head
single function shower handset
minimum operating pressure 1 bar MP

FINISH:

Bright Nickel

MINIMUM OPERATING PRESSURE:

1.0 bar MP



Timeless Design. Pioneering Performance.

BOOTH & Co.
ENGLAND

Your journey to distinction awaits.

01934 744466 | sales@vado.com | www.vado.com/booth-and-co

TECHNICAL DRAWING

COLLECTION: AXBRIDGE

PRODUCT CODE: BC-AXB-149/RRK-BN

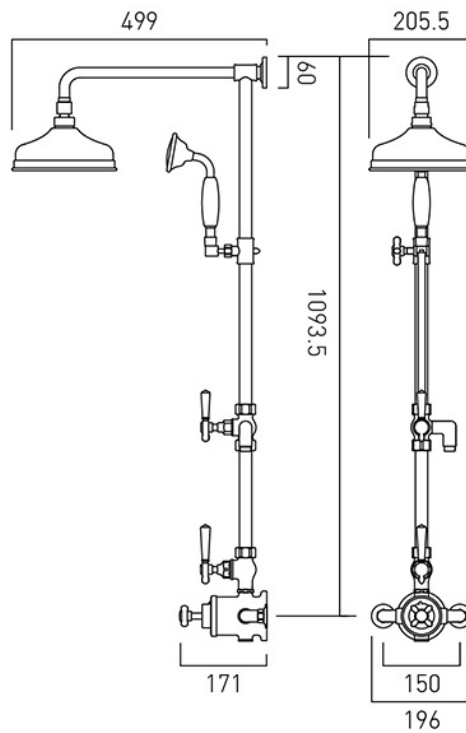

Timeless Design. Pioneering Performance.

BOOTH & Co.
ENGLAND

Your journey to distinction awaits.

01934 744466 | sales@vado.com | www.vado.com/booth-and-co