

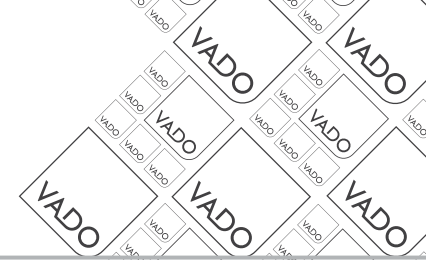

where inspiration flows

# GROOVE



Installation Guide  
Illuminated Mirrors

This instruction booklet covers these models:

GRV-M6I-FLS-R0, GRV-M6I-FLS-SQ,  
GRV-M8I-FLS-R0, GRV-M8I-FLS-SQ  
(All finish options)

GRV-M6I-FLS-R0  
GRV-M6I-FLS-SQ  
GRV-M8I-FLS-R0  
GRV-M8I-FLS-SQ

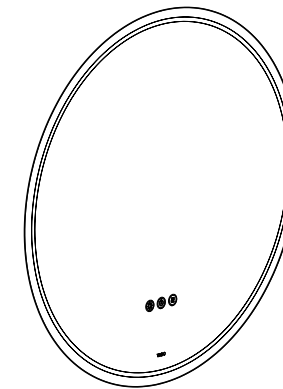

GRV-M8I-FLS-R0

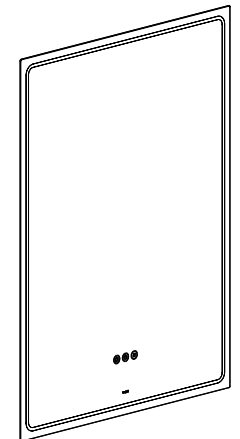

GRV-M8I-FLS-SQ

Vado  
Wedmore Road, Cheddar, Somerset, England BS27 3EB  
tel 01934 744466. fax 01934 744345  
aftersales@vado.com  
www.vado.com



## Important - Please Read

**VADO** reserves the right to make technical improvements and enhance the appearance of the products included in this instruction manual.

Please read these instructions carefully before starting the installation and keep for future reference.

Remove all packaging and check the product for missing parts or damage before starting installation.

Any alterations made to this product and fittings may infringe water regulations and will invalidate the guarantee.

Please take great care when installing this product not to damage its surface.

The plumbing codes applicable in the respective countries must be observed.

To avoid the risk of electrocution, please turn off the mains electricity supply before commencing installation.

This installation guide details fitting to a solid wall. For other substrates, please use appropriate fixings and joists (if required). Ensure the wall can take weight of units detailed within this guide.

Double check all measurements to ensure accuracy during the installation.

## Electrical Installation

All electrical connections should be carried out by a qualified electrician and be in compliance with Part P regulations. The installation must comply with current NICEIC regulations and to the requirements of BS7671 (Requirements for electrical installations).

Please ensure that all exposed metal is supplementary bonded. Always switch off the power at the main consumer unit and isolate the electrical supply before making any electrical connections. This appliance is to be fitted with the relevant RCD protection.

### Electrical Connection:

Input (IN): 220-240 V; 50 Hz

## Cleaning Instructions

The coating on this product is finished to the highest standard. Due care needs to be taken to ensure the appearance is retained.

We recommend cleaning all products with a soft damp cloth **ONLY** and advise strongly against the use of all aggressive/corrosive cleaning products i.e. powders and liquids. If these instructions are not followed, this may invalidate your guarantee in the event of a problem occurring.

## Important - please read

VADO Groove Illuminated mirrors are IP44 rated and are suitable for installation in zone 2 and beyond. The diagram below illustrates this zonal concept and must be followed to ensure safe installation of electrical bathroom products.

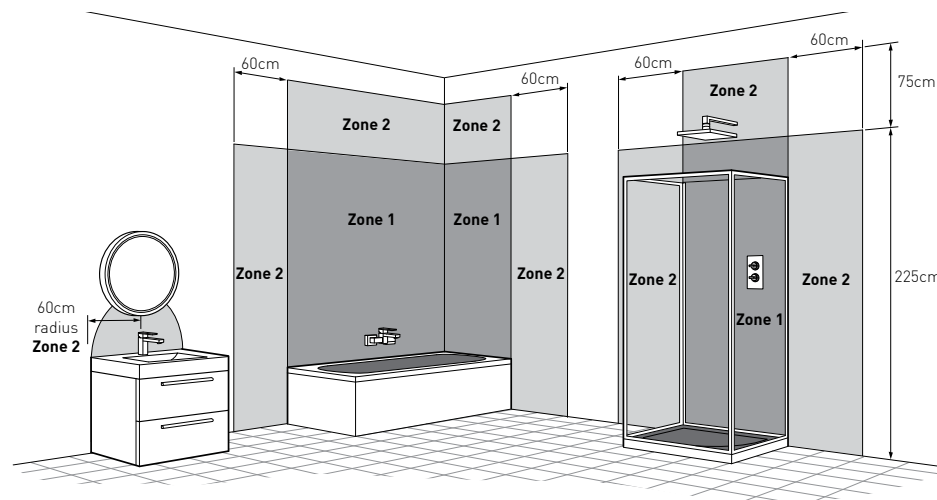

- **Zone 0** - Inside the Bath or Shower.
- **Zone 1** - Area above the Bath or Shower tray to an height of 2.25m (minimum IP Rating of IPX4 is required alongside RCD protection).
- **Zone 2** - Area outside of Zone 1 (minimum IP Rating of IPX4 is required).

This appliance can be used by children (aged 8 years and above) and persons who are physically or mentally handicapped, have restricted sensory capabilities or lack of experience if they have been given supervision or instruction concerning the use of the appliance in a safe way and understand the hazards involved. Do not allow children to play with the appliance.

## Disposal

### Waste electrical and electronic equipment (WEEE)

DO NOT dispose of this unit with normal household waste, take to a local authority recycling centre.



This product contains a light source of energy efficiency class E

# Contents of Packaging

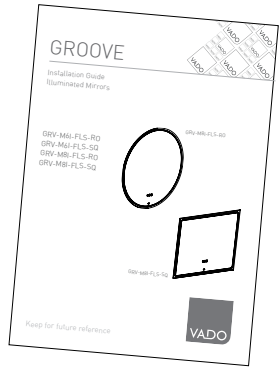

Installation guide

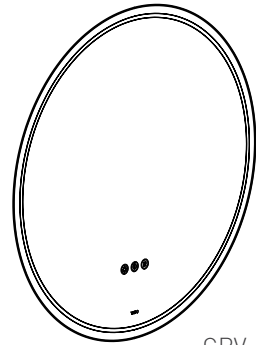

GRV-M6I-FLS-RO

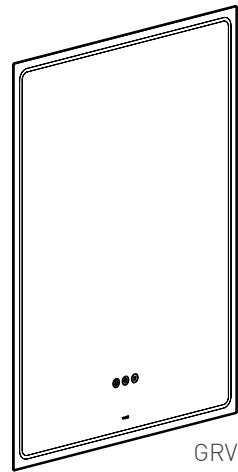

GRV-M6I-FLS-SQ

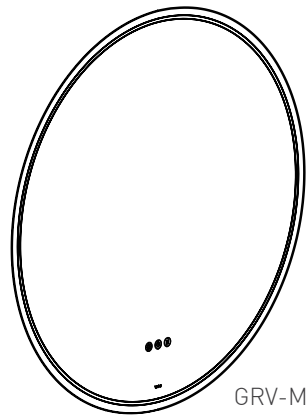

GRV-M8I-FLS-RO

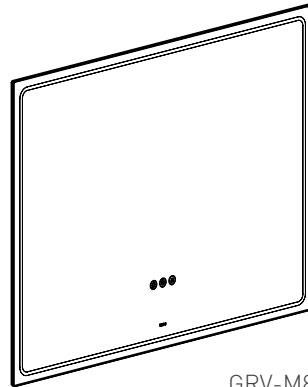

GRV-M8I-FLS-SQ

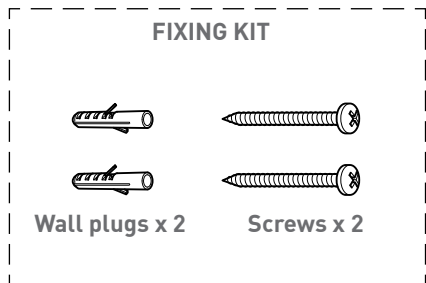

# Dimensions (All mirrors have a 1m power cord)

GRV-M6I-FLS-RO

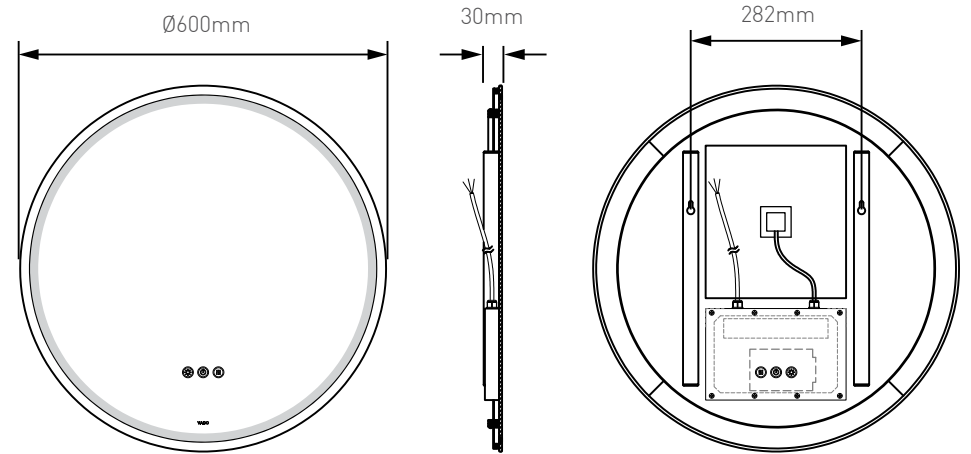

GRV-M8I-FLS-RO

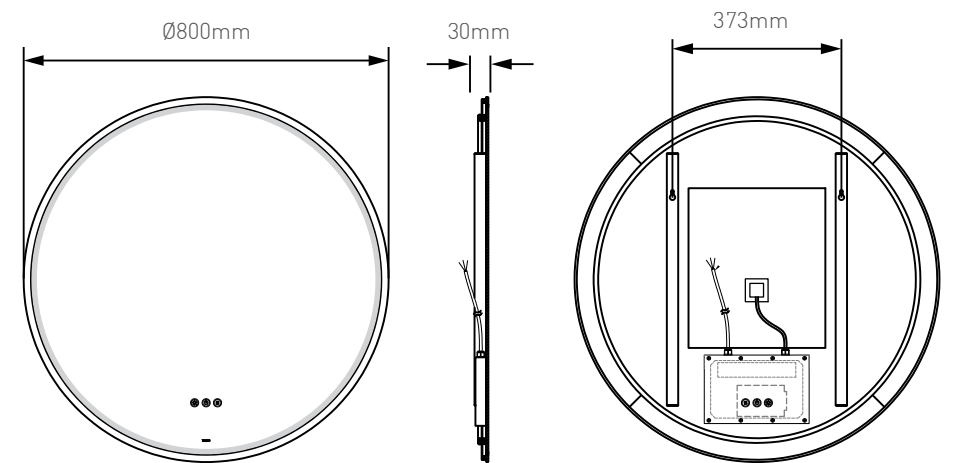

Dimensions - GRV-M6I-FLS-SQ (All mirrors have a 1m power cord)

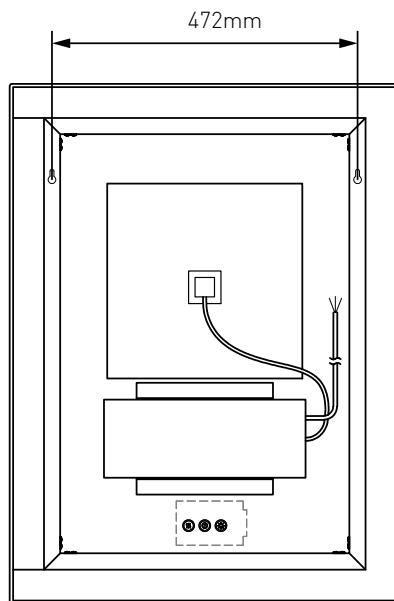
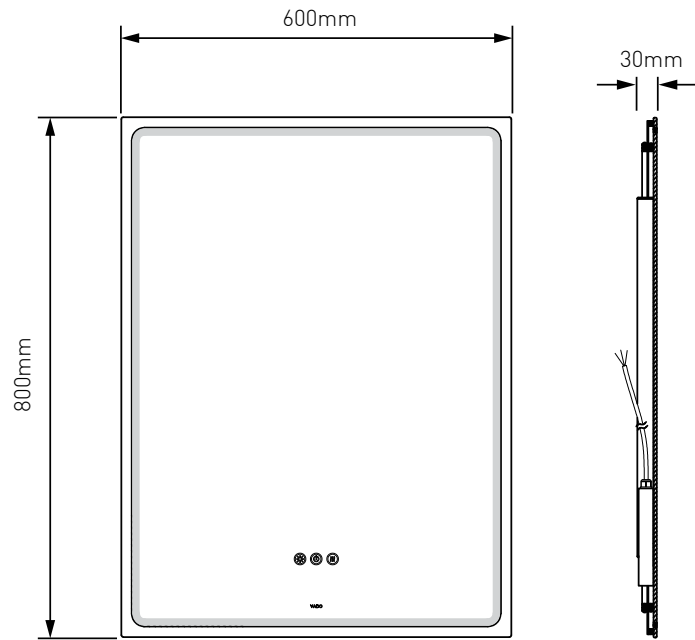

Dimensions - GRV-M8I-FLS-SQ (All mirrors have a 1m power cord)

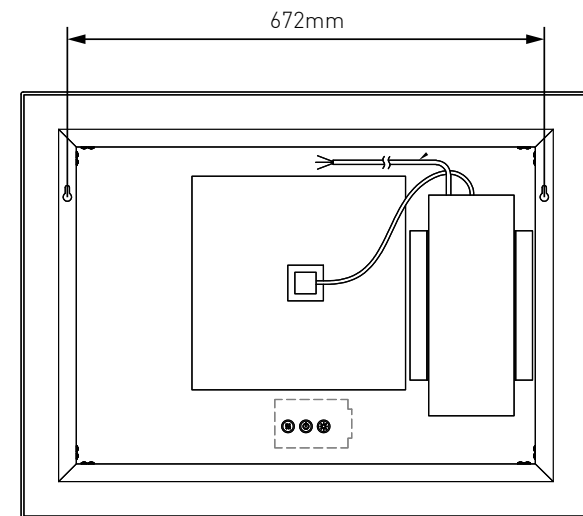
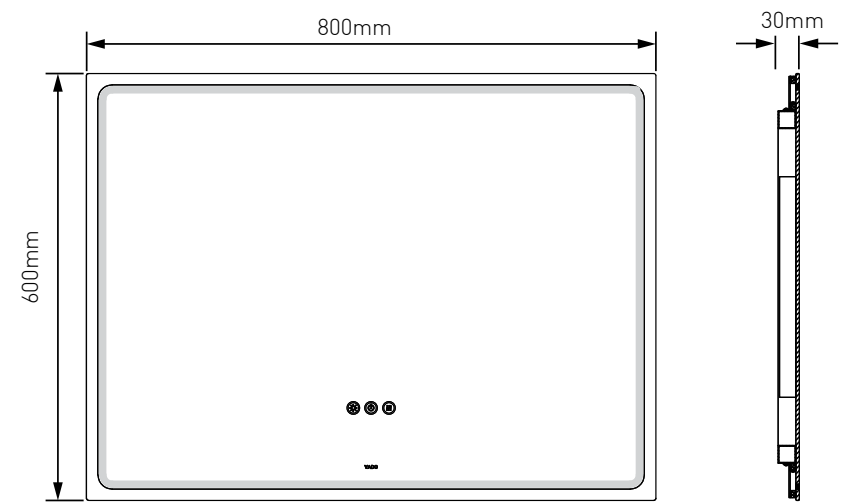

# Installation

**1**

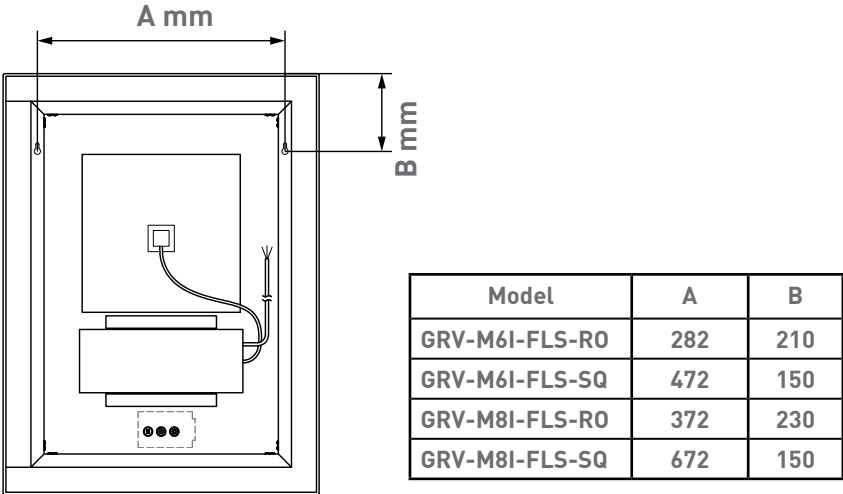

Model	A	B
GRV-M6I-FLS-RO	282	210
GRV-M6I-FLS-SQ	472	150
GRV-M8I-FLS-RO	372	230
GRV-M8I-FLS-SQ	672	150

Measure and note the distance between the centres of the two mounting keyholes (**A & B**).

**2**

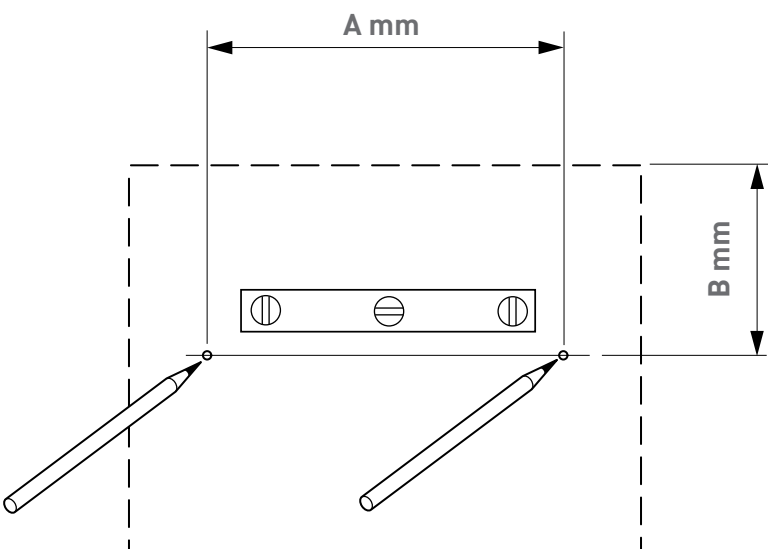

Determine the desired location of the mirror (considering the safety zone requirements) mark with a pencil. Using a level mark the hole locations on the wall.

# Installation

**3**

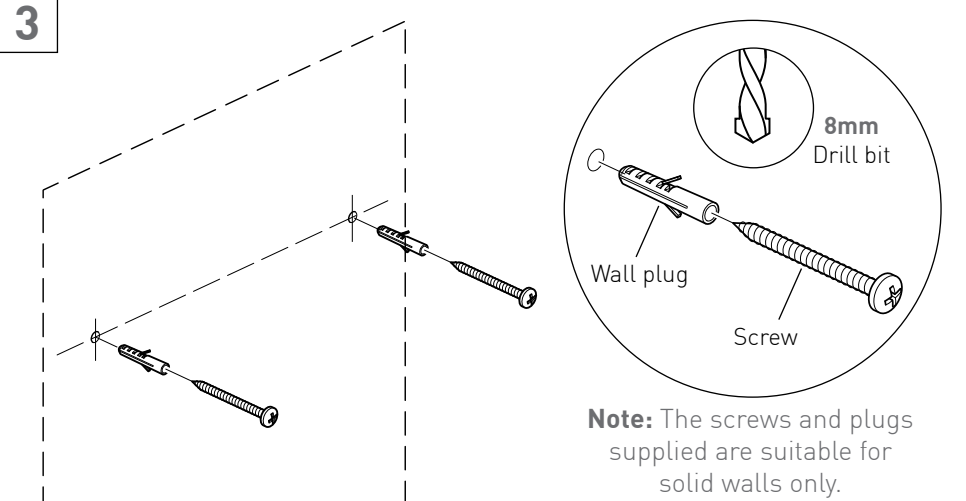

**Note:** The screws and plugs supplied are suitable for solid walls only.

Using a suitable drill bit for your wall, drill the two mounting holes and fit the wall plugs level with the surface of the wall. If fitting to a tiled surface, wall plugs should be inserted below the tile surface to prevent cracking. Screw the supplied fixings into wall plugs ensuring that they are left protruding enough to mount the mirror.

**4**

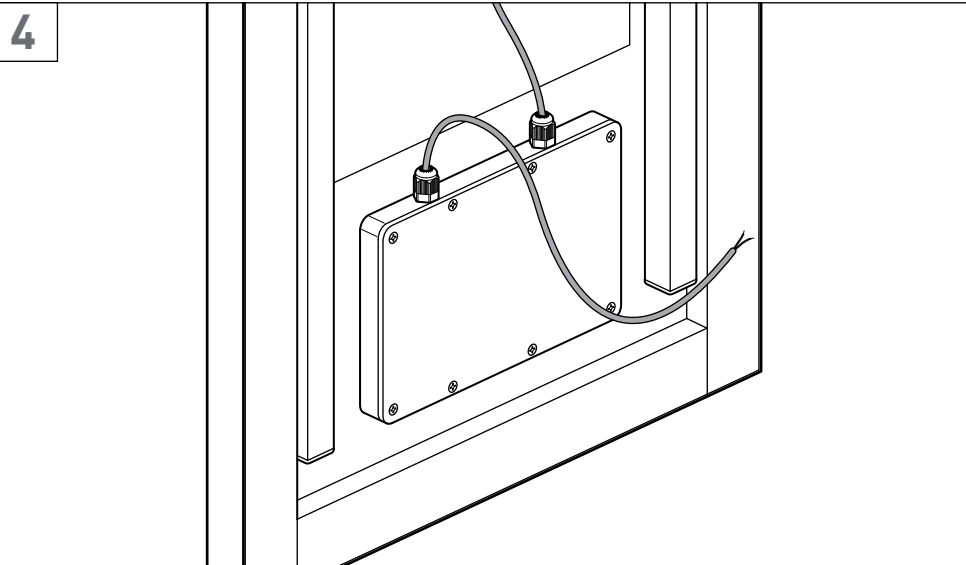

Wire the mirror to your mains supply.

## Installation

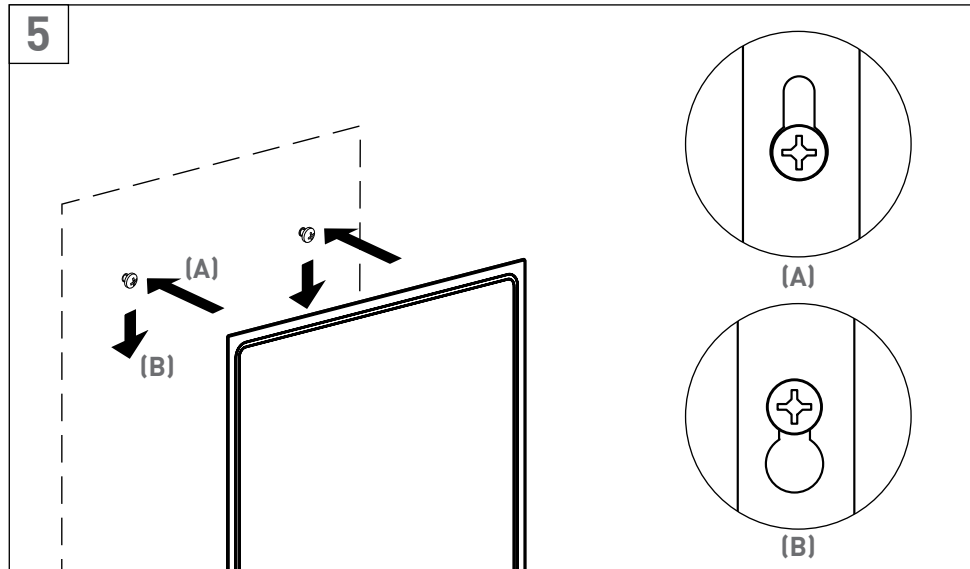



Carefully mount the mirror on the two protruding mounting screws **(A)**. The keyholes will allow the mirror to drop into position **(B)**.

### 6 Operation

Press  to turn on/off the defogger \*

Press  to turn on the frontlight only

Press  again to turn on the backlight only

Press  for a third time to turn the front and backlight on together

Press  for a fourth time to turn off both lights

Press  to switch between 3 light temperatures

Hold  to gradually cycle the brightness/temperature (2700k to 6500k)

\*The defogger will turn off automatically after 30 minutes.

## Guarantee

This VADO illuminated mirror comes with a 2 year guarantee as standard. Within this guarantee period, VADO will provide replacement parts and any labour **[SEE NOTE 1]** needed to complete the product repair. This standard guarantee may be extended by registering your product on our website at: <https://www.vado.com/support/guarantee> Once registered this mirror will have a 5 year guarantee (2 years parts and labour plus 3 years parts only) **[SEE NOTE 2]**.

### Guarantee Conditions

Our products are guaranteed against manufacturing defects from the date of purchase until the expiry of the relevant guarantee period shown above.

The guarantee is only valid if:

- The product has been installed, used and maintained in accordance with VADO's instructions and subjected to normal use only.
- The defect is not due to the use of an unsuitable or inadequate power supply.
- The defect is not due to accident, misuse, neglect, or incorrect/inappropriate repair (other than by VADO or VADO authorised agents) or damage caused by foreign objects or substances.
- The extended guarantee is only available if you have completed the guarantee registration process.

This can be done via the VADO website or via telephone to our Aftersales team.

Registration must be completed within 6 months from the date of purchase. Under the extended guarantee period, VADO will, at its option, offer to supply any replacement product (or component part) assessed to be defective **[SEE NOTE 3]**.

- The guarantee (whether standard or extended) is non-transferable to any subsequent owner.

All claims under the guarantee should be notified in the first instance to our Aftersales department, contact details below, this must be done no later than the last day of the relevant guarantee period.

All claims must be accompanied by proof of purchase (sales receipt or delivery note) from an official VADO dealer.

The guarantee does not extend to any consequential loss or damage.

After repair or replacement, the relevant guarantee period will be calculated from the original date of purchase.

VADO operates a policy of continuous product development and therefore reserves the right to change the product, packaging and documentation specifications without notice.

In situations where like-for-like replacements are not possible, VADO will endeavor to provide the closest alternative. E&OE.

### NOTES:

**[1]** Labour via our engineer network is only available in the UK. Attendance by a VADO engineer or sub-contract engineer will be under our standard terms and conditions.

**[2]** Excludes any electrical components.

**[3]** VADO reserves the right to charge in advance for a product (or replacement part) pending collection and investigation (at VADO expense) to confirm a defect is due to a manufacturing issue.

If a defect is found the charge will be refunded or cancelled.

This guarantee is in addition to and does not affect your statutory rights as a consumer.

Tel: 01934 745163

Email: [aftersales@vado.com](mailto:aftersales@vado.com)