

Important - Please Read

VADO reserves the right to make technical improvements and enhance the appearance of the products included in this instruction manual.

Please read these instructions carefully before starting the installation and keep for future reference.

Remove all packaging and check the product for missing parts or damage before starting installation.

Any unadvised alterations made to this product will invalidate the guarantee.

Please take great care when installing this product to avoid damage to its surface.

This installation guide details fitting to a solid wall. Ensure the wall can take weight of units detailed above.

Please note that some units are heavy. Take care when lifting, and follow health and safety guidelines. It is recommended that 2 people carry out the installation of larger basin/vanity units over 30Kgs gross weight.

Check for any hidden pipes or electrical cables before drilling holes in the wall.

When deciding where to install the vanity consider the potential overhang.

Double check all measurements to ensure accuracy during the installation.

Important - Preparation wall hung units

Recommended install heights

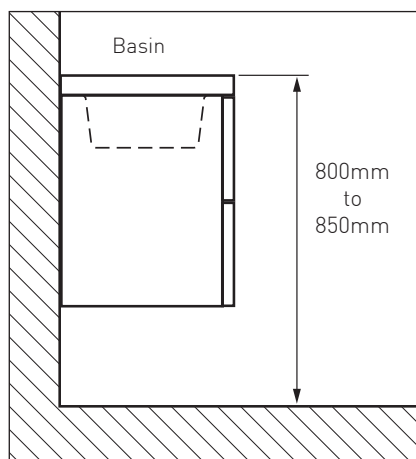

Contents of Packaging

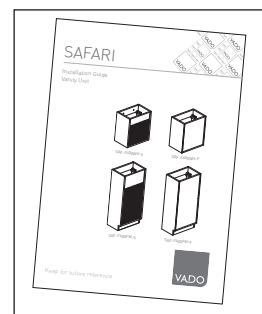

Installation guide

Wall & floor units to suit

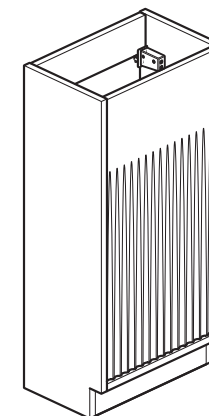
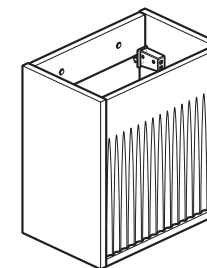

HANDLE OPTIONS (with supplied screws)



SAF-HANK-S



SAF-HANK-F



SAF-HANP-F

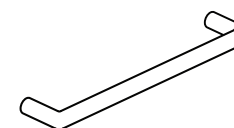

SAF-HANB

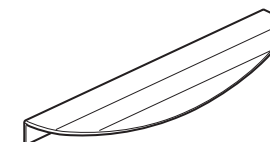

SAF-HANT

FIXING KIT

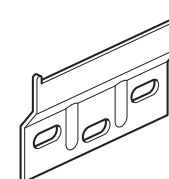

Wall Brackets x 2



Wall plugs x 6

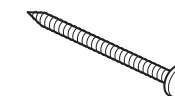

Screws x 6

Dimensions - Wall & floor units

Wall units

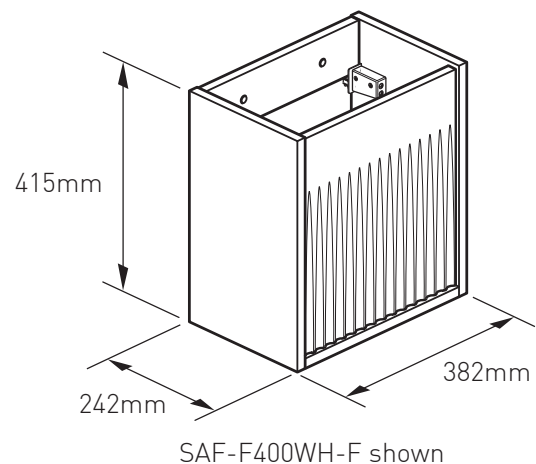

Floor units

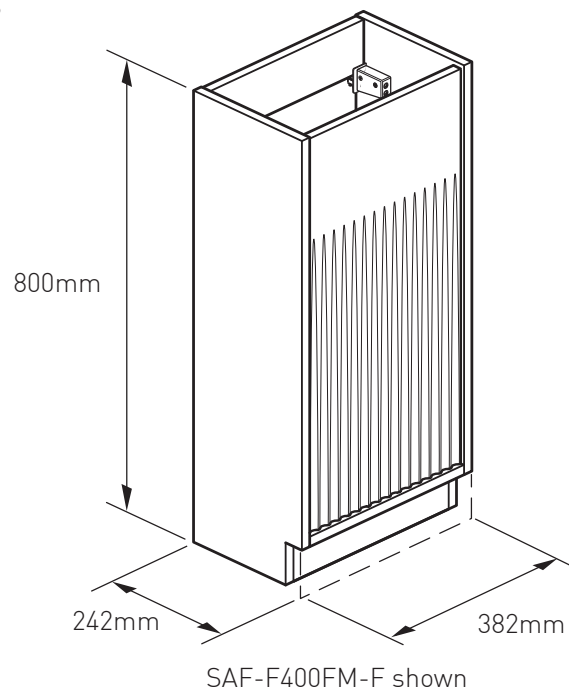

Installation

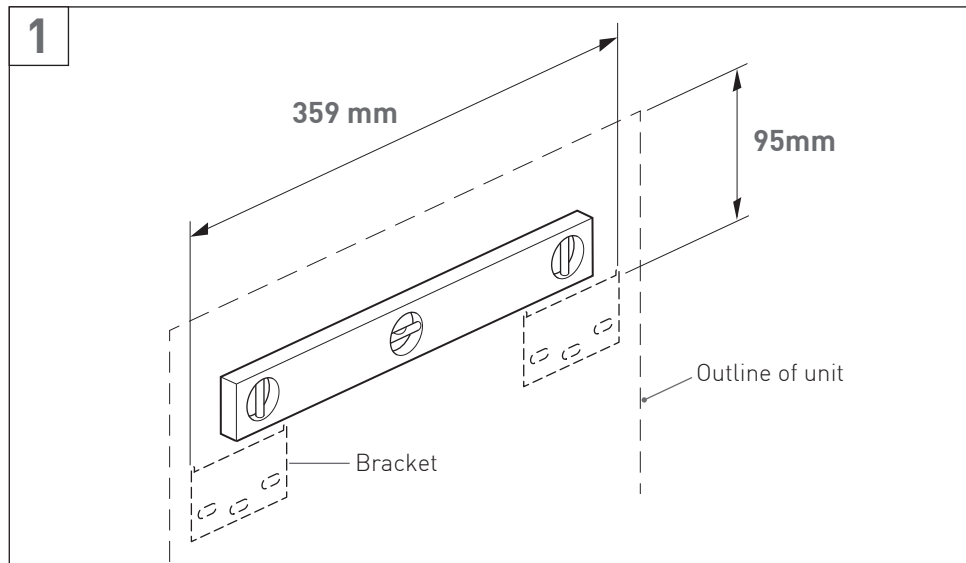

Decide on the position and height of the unit. The recommended basin height is between 800 and 850mm from floor to top of basin. Mark the bracket fixing holes onto the wall. **NOTE:** The dimensions are for the maximum width over the brackets.

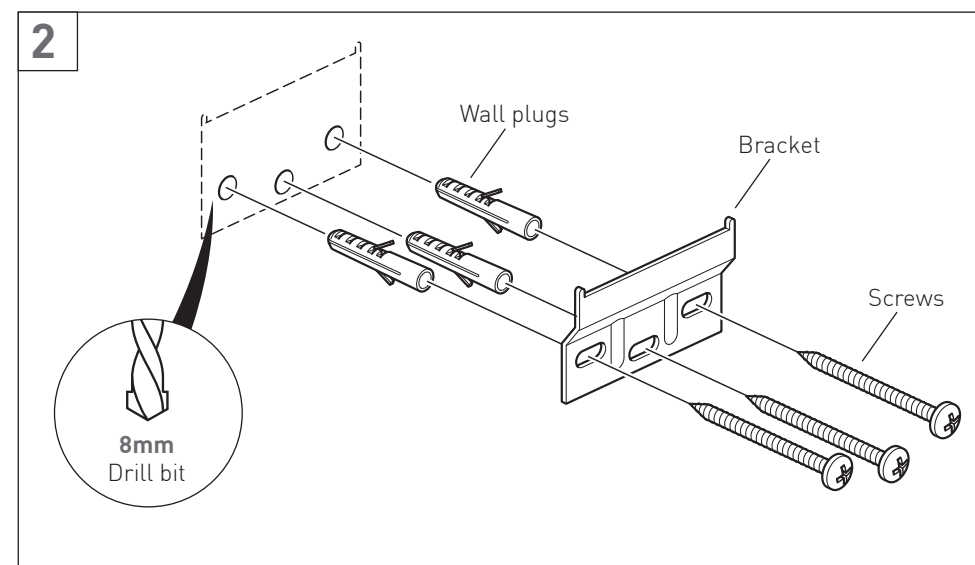

Drill \varnothing 8mm holes, insert the wall plugs and screw on the brackets. **NOTE:** If the vanity unit and/or basin are not fitted level this may prevent the basin from draining correctly.

Installation

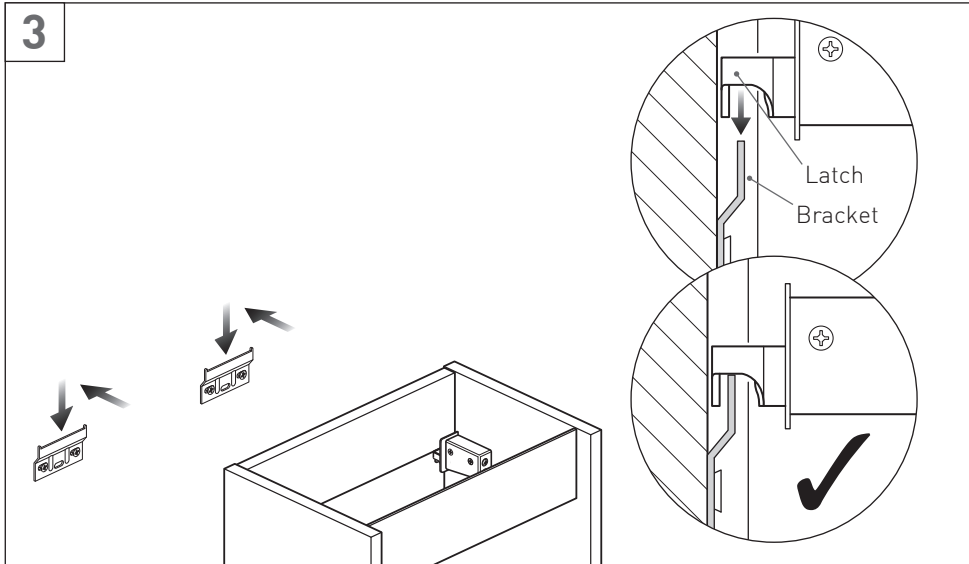

With two people lift the unit over and onto the brackets, make sure that both latches are over the brackets before releasing the unit.

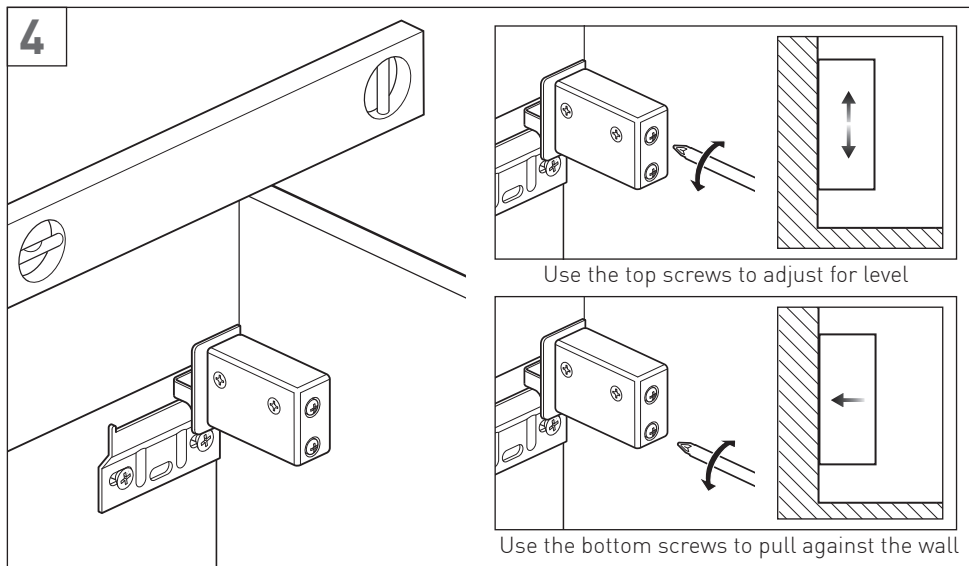

Check the unit is level. If leveling is required, use the top screw on both sides to lower or lift the unit.

Once level, use the bottom screws on the hangers to clamp the unit to the wall.

Installation - Door adjustment

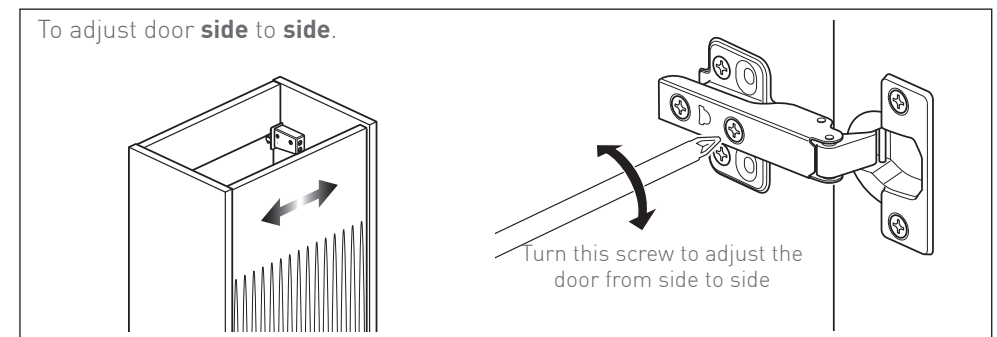
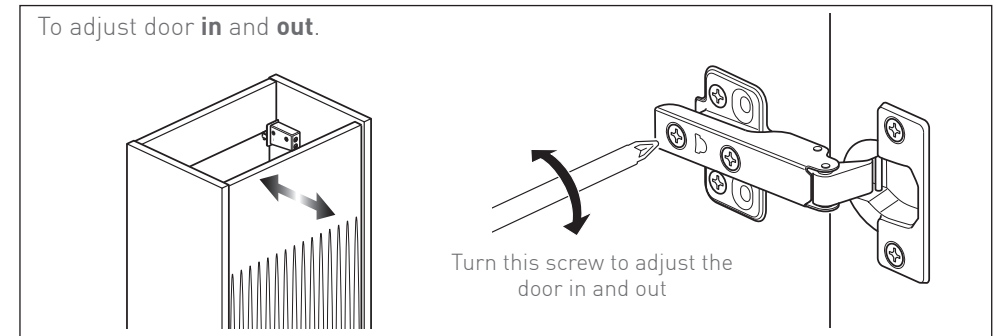

Installation - door handles

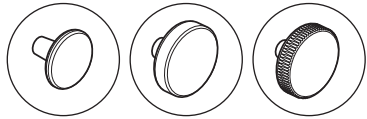

HANK-S-SML HANK-S HANK-F

Decide a position in the top corner on the **opposite side to the door hinge**.

Mark a position in the top corner on the front face using 2.5mm drill bit. Drill again using a 5mm drill bit. Attach the handle using the screw provided.

Note: Make sure your drill is set at exactly 90 degrees to the door's surface.

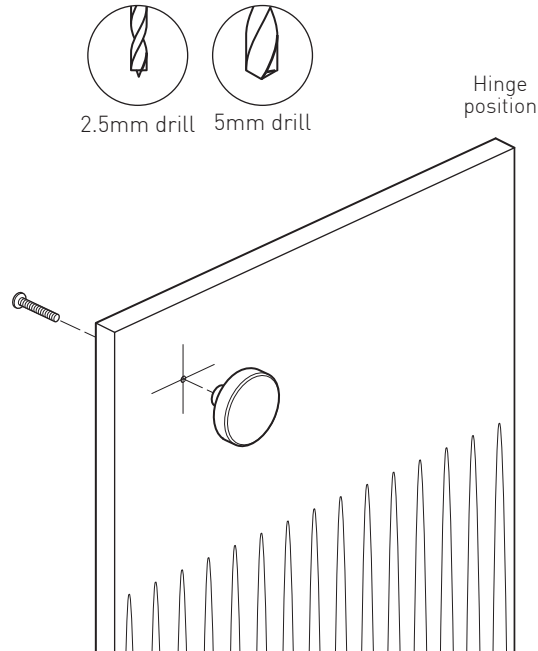

SAF-HANP-F

Decide a position in the top corner on the **opposite side to the door hinge**.

Position the handle and mark the screw points, the holes are 40mm apart. Drill a starter hole through the front face using 2.5mm drill bit. Drill again using a 5mm drill bit.

Ensure it's level, and attach using the screws provided.

Note: Make sure your drill is set at exactly 90 degrees to the door's surface.

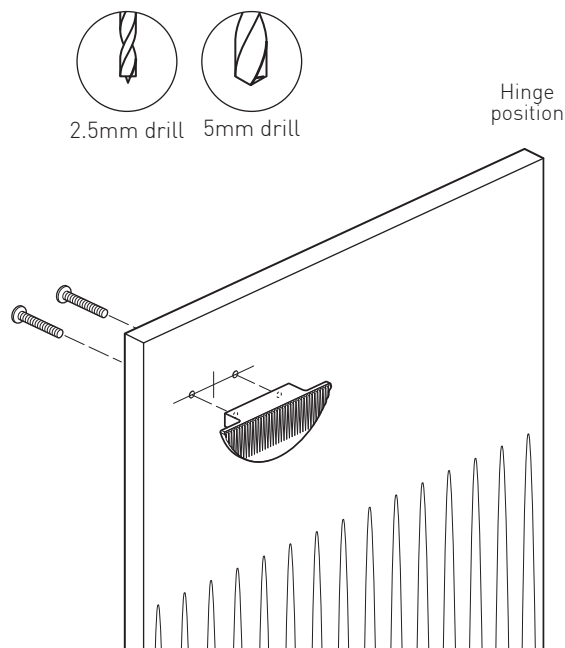

Installation - door handles

SAF-HANB

Decide a position in the top corner on the **opposite side to the door hinge**.

Position the handle and mark the screw points, the holes are 155mm apart. Drill a starter hole through the front face using 2.5mm drill bit. Drill again using a 5mm drill bit. Attach the handle using the screw provided.

Note: Make sure your drill is set at exactly 90 degrees to the door's surface.

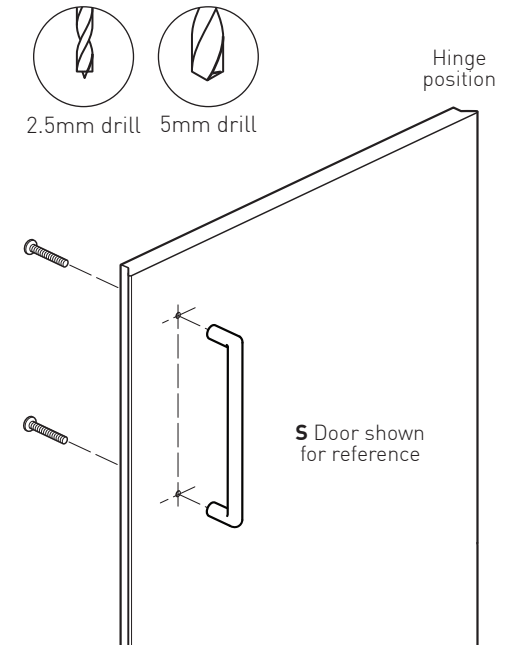

SAF-HANT

Line up the handle on the back of the door making sure the handle is flush to the end of the door, mark the three holes.

From the back drill a **short** pilot hole in the three positions. **Be careful not to go through the whole drawer.**

Screw on the handle using the screws provided.

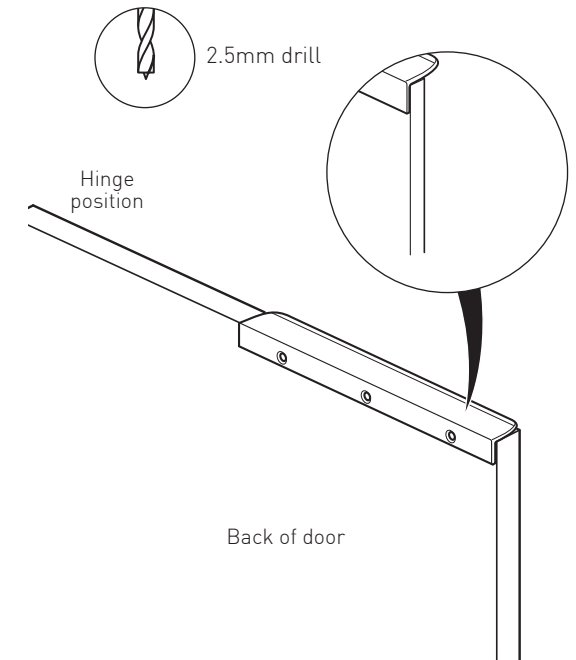

Installation - Basins

Apply silicone non-acidic to the side and front edges of the unit. Carefully position the basin down onto the unit ensuring that it is centrally positioned and flush at the back.

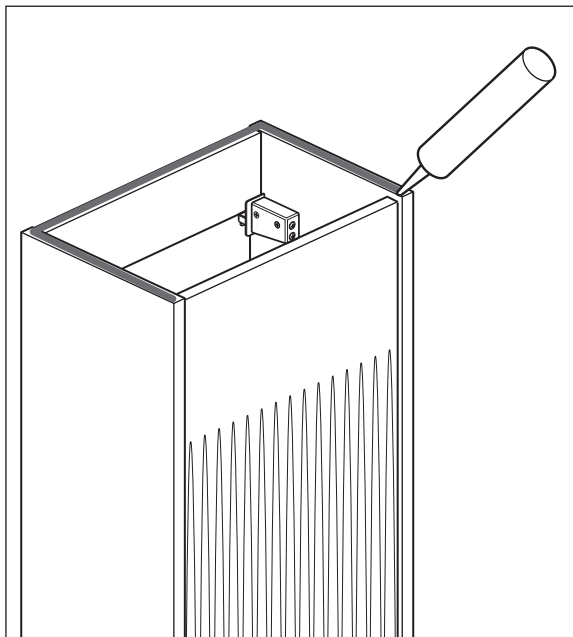

Apply a bead of silicone along the back and sides of the basin. Allow to set fully.

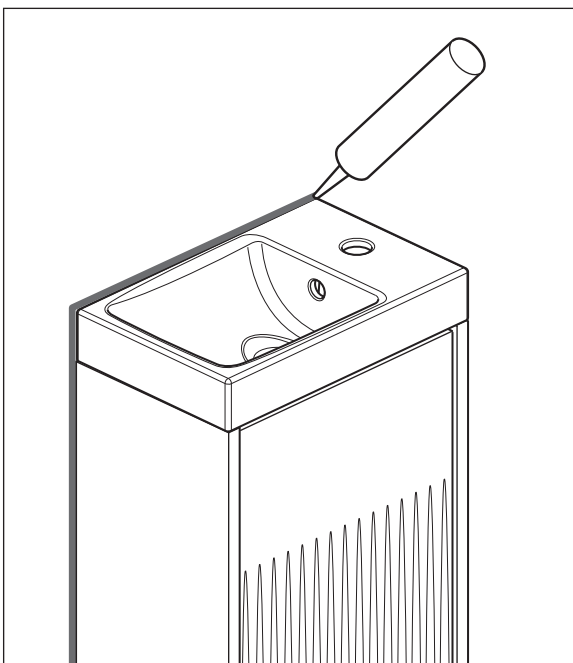

Cleaning Instructions

The coating on this product is finished to the highest standard. Due care needs to be taken to ensure the appearance is retained. We recommend cleaning all products with a soft damp cloth ONLY and advise strongly against the use of all aggressive/corrosive cleaning products i.e. powders and liquids. If these instructions are not followed, this may invalidate your guarantee in the event of a problem occurring.

⚠ Note: Bathroom furniture will deteriorate through extended exposure to elevated levels of condensation. To mitigate this, it is imperative that bathrooms are equipped with an appropriate ventilation system, such as an extractor fan.

Notes:

Notes:

Guarantee

This VADO vanity unit comes with a 2 year guarantee as standard. Within this guarantee period, VADO will provide replacement parts.

This standard guarantee may be extended by registering your product on our website at: <https://www.vado.com/support/guarantee>. Once registered this vanity unit will have a 6 year guarantee.

Guarantee Conditions

Our products are guaranteed against manufacturing defects from the date of purchase until the expiry of the relevant guarantee period shown above.

The guarantee is only valid if:

- The product has been installed, used and maintained in accordance with VADO's instructions and subjected to normal use only.
- The defect is not due to accident, misuse, neglect, or incorrect/inappropriate repair (other than by VADO or VADO authorised agents) or damage caused by foreign objects or substances.
- The extended guarantee is only available if you have completed the guarantee registration process.

This can be done via the VADO website or via telephone to our Aftersales team.

Registration must be completed within 6 months from the date of purchase. Under the extended guarantee period VADO will, at its option, offer to supply any replacement product (or component part) assessed to be defective **[SEE NOTE 1]**.

- The guarantee (whether standard or extended) is non-transferable to any subsequent owner.
- Mould, Mildew build up, the effects of limescale and corrosion are not covered under this guarantee.
- This guarantee does not cover damage and/or malfunction caused by inappropriate cleaning (please refer to our recommended care and maintenance guidelines).
- Damage to VADO furniture caused by standing water or inadequate room ventilation is not covered under this guarantee.

All claims under the guarantee should be notified in the first instance to our Aftersales department, contact details below, this must be done no later than the last day of the relevant guarantee period.

All claims must be accompanied by proof of purchase (sales receipt or delivery note) from an official VADO dealer.

The guarantee does not extend to any consequential loss or damage.

After repair or replacement, the relevant guarantee period will be calculated from the original date of purchase.

VADO operates a policy of continuous product development and therefore reserves the right to change the product, packaging and documentation specifications without notice.

In situations where like-for-like replacements are not possible, VADO will endeavour to provide the closest alternative. E&OE.

NOTES:

[1] VADO reserves the right to charge in advance for a product (or replacement part) pending collection and investigation (at VADO expense) to confirm a defect is due to a manufacturing issue. If a defect is found the charge will be refunded or cancelled.

This guarantee is in addition to and does not affect your statutory rights as a consumer.

Tel: 01934 745163

Email: aftersales@vado.com