

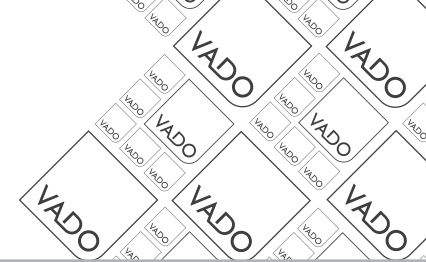

where inspiration flows

# SAFARI



Installation Guide

Single function mini shower kit with outlet

This instruction booklet covers these models:

SAF-SFMKWO  
(All finish options)

SAF-SFMKWO

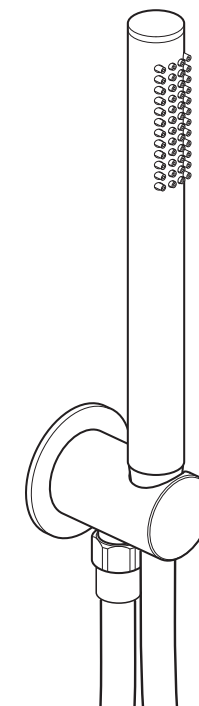

Vado  
Wedmore Road, Cheddar, Somerset, England BS27 3EB  
tel 01934 744466. fax 01934 744345  
aftersales@vado.com  
www.vado.com



## Important - please read

Please read these instructions carefully before starting installation and keep for future reference.

Remove all packaging and check the product for missing parts or damage before starting installation.

Any alterations made to this product and fittings may infringe water regulations and will invalidate the guarantee.

The installation must comply with all Local/National Water Supply Authority Regulations/Byelaws and Building and Plumbing Regulations.

To be installed in accordance with BS EN806.

We strongly recommend that you use a qualified and registered plumber.

## General installation

When installed, the fitting must comply with the requirements of the Water Supply (Water Fittings) Regulations 1999 and Scottish Byelaws 2004.

For further information, contact the Water Regulations department of your local water supplier (see the WRAS website [www.wras.co.uk](http://www.wras.co.uk) for details) or the Water Regulations Advisory Scheme by email ([info@wras.co.uk](mailto:info@wras.co.uk)) or telephone: 01495848454.

Please take great care when installing this product not to damage its surface.

Please note if installing in an enclosed environment, access should be left for servicing and maintenance. No costs relating to inadequate access can be accepted.

## Contents of Packaging

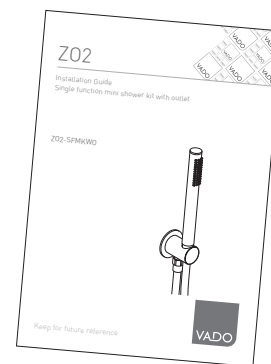

Installation guide &  
User manual

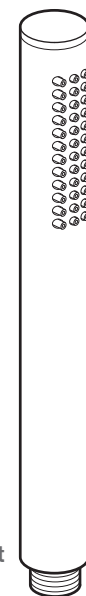

Handset

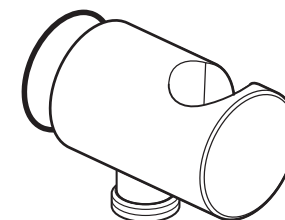

Outlet / Handset holder  
with O-ring



Flow regulator

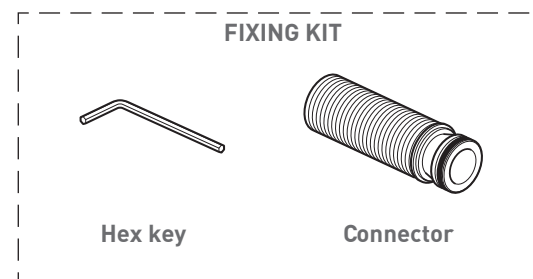

FIXING KIT



Hex key

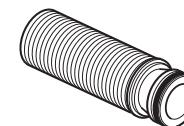

Connector



Shroud

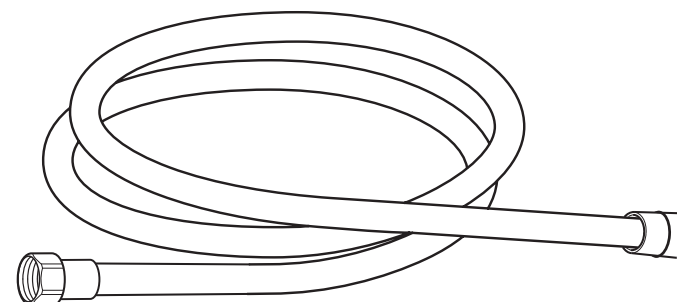

Shower hose

# Dimensions

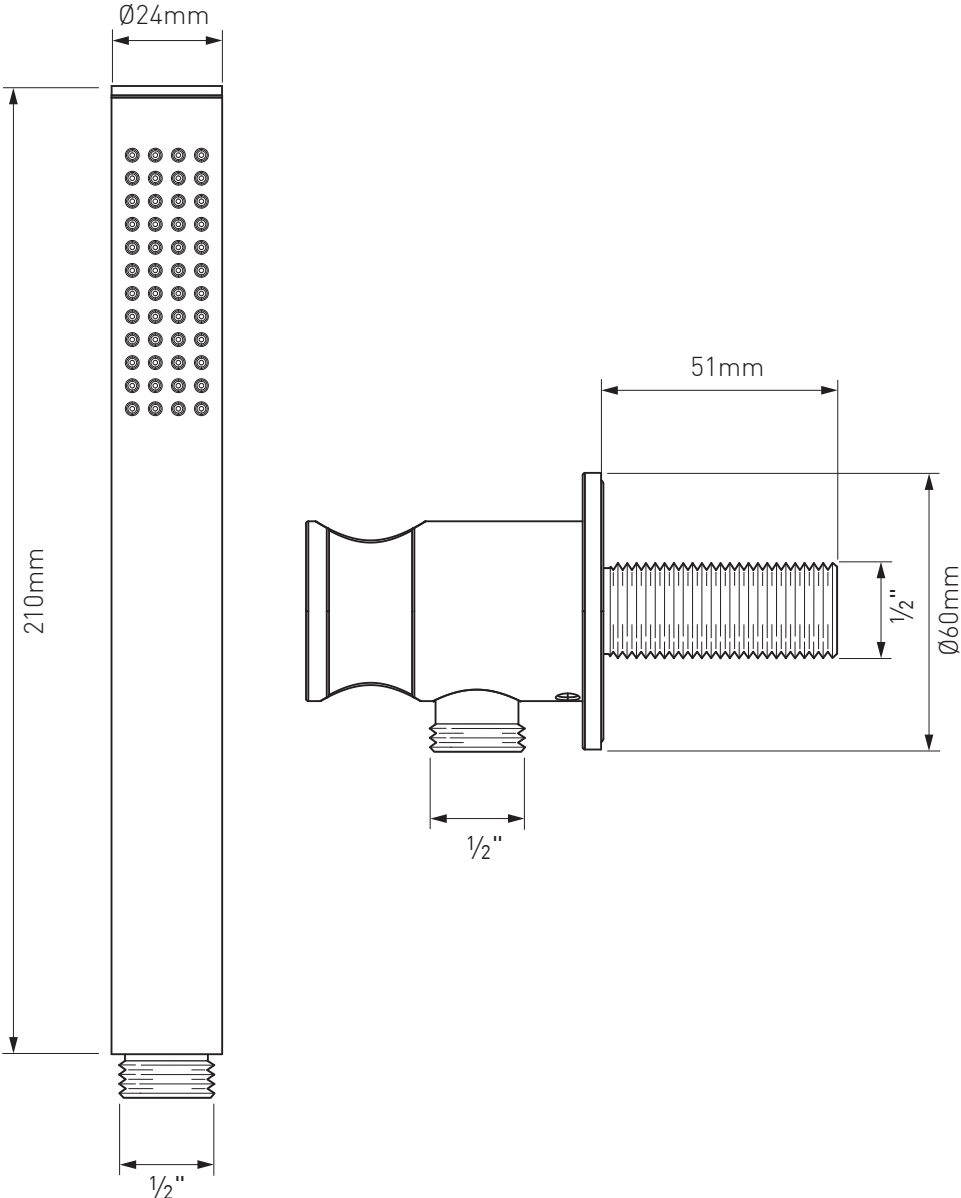

# Installation quick guide

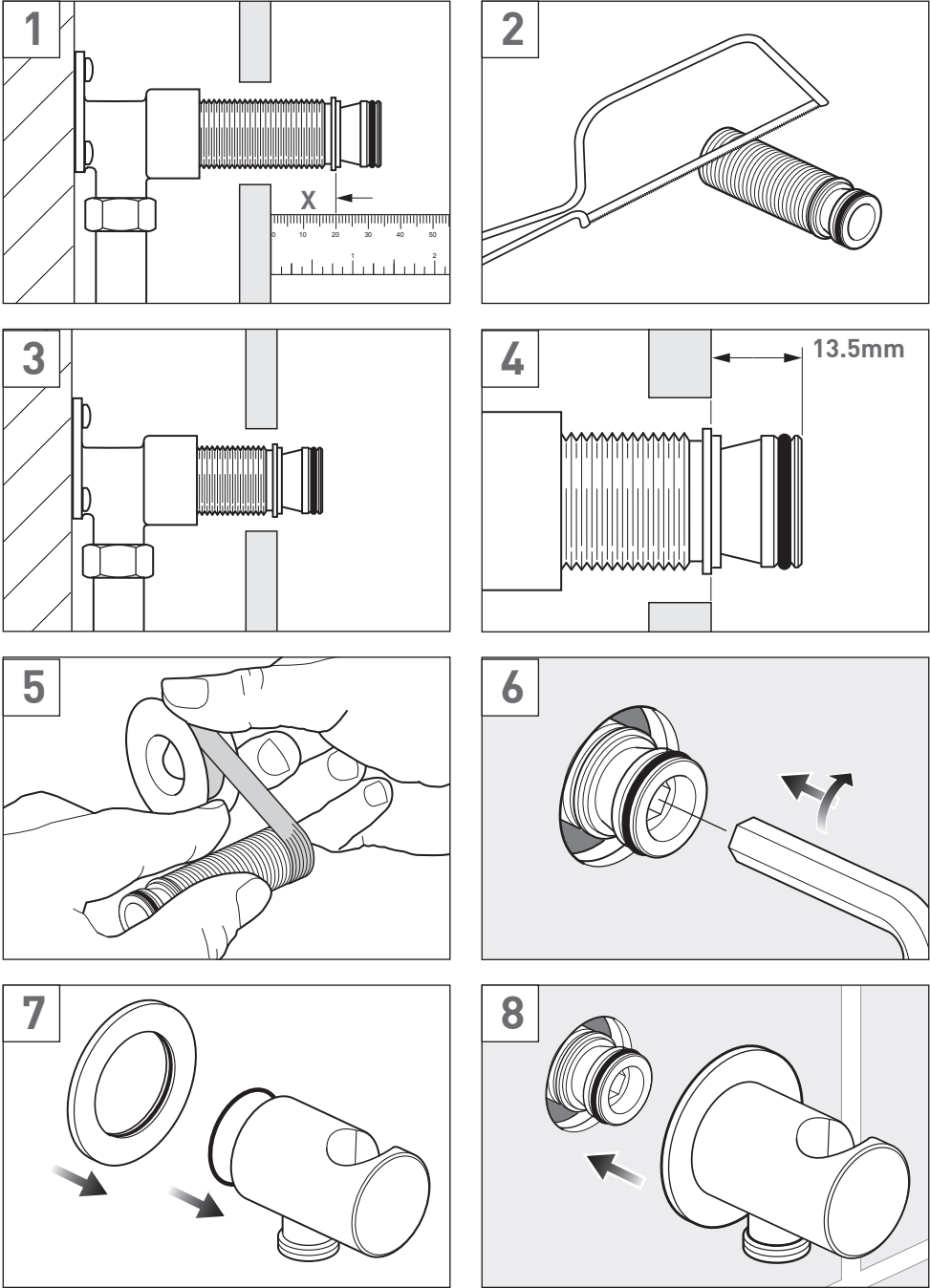

## Installation quick guide

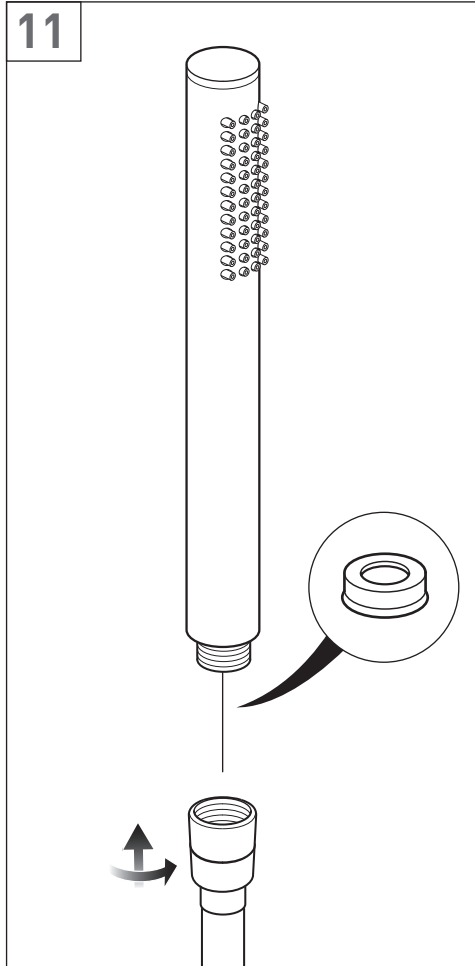
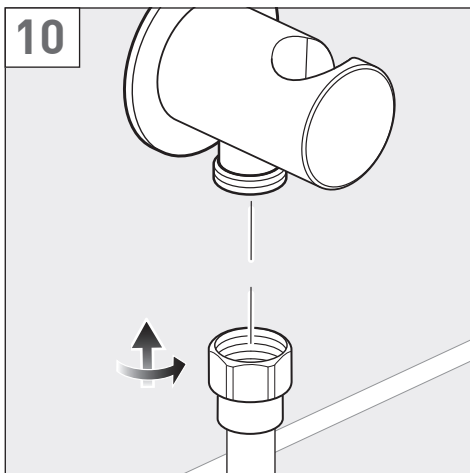
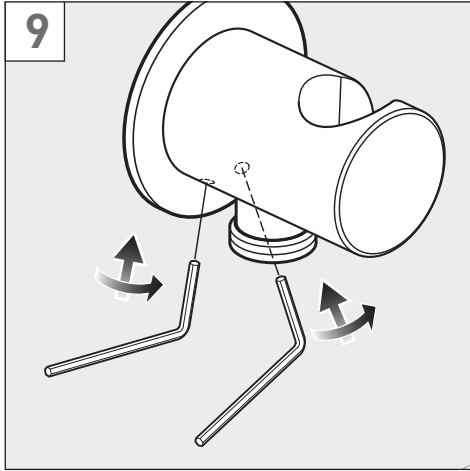

## Installation

Prepare the wall with a 1/2" connector (a fixed elbow is shown on the right, this is not supplied). Connect the water supply from the valve. Check for leaks, and finish off the wall.

Screw in the supplied inlet connector. Take the measurement from the finished wall surface to the outside shoulder of the connector (**Xmm**).

Remove the connector from the elbow. If necessary carefully cut the bottom of the connector by this measurement (**Xmm**). Remove any burrs.

Check the length of the connector by screwing into the elbow.

The distance between the wall and the end of the connector should be 13.5mm. Remove the connector.

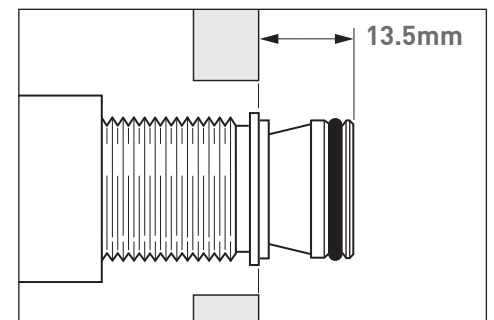
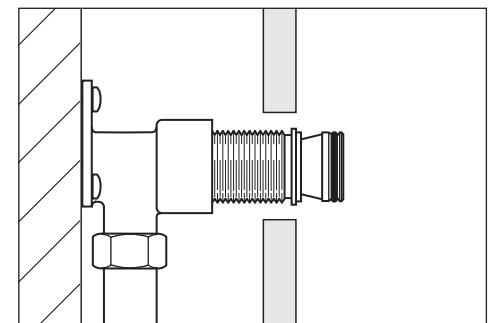
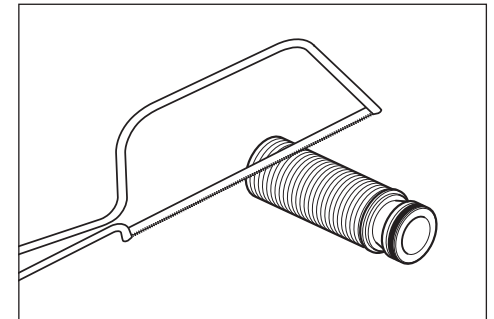
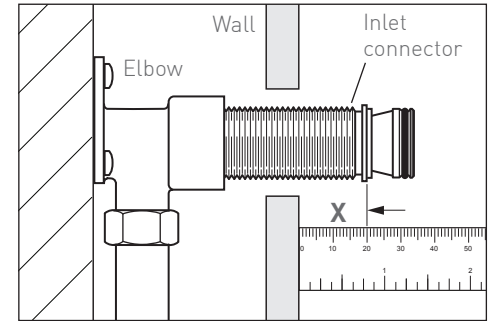

## Installation outlet

Use PTFE tape on the connector.

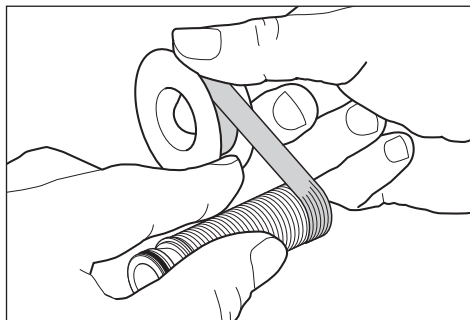

Screw in the connector and tighten using a hex key in the end of the connector.

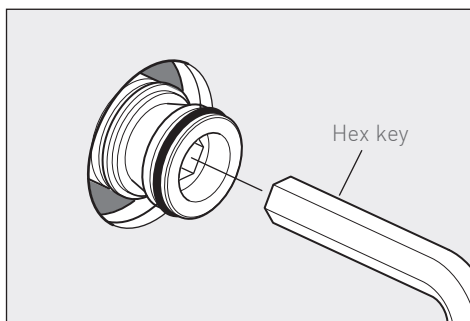

Make sure that the o-ring is in place in the groove at the back of the outlet.

Slide on the shroud.

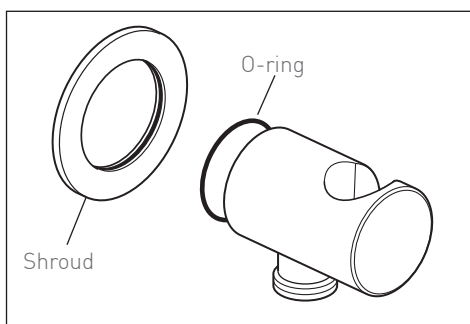

Carefully slide the outlet over the connector and against the wall, make sure that the outlet is pointing downwards.

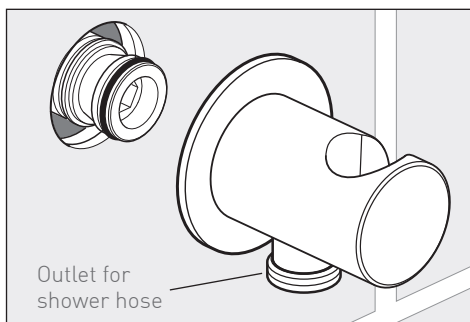

## Installation

Tighten the grub screw on the underside using a hex key.

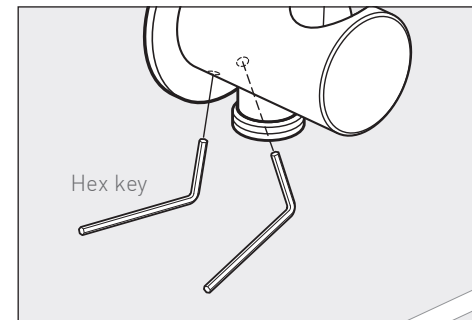

### Shower hose connection

Make sure there is a rubber washer in the cone end of the shower hose and screw onto the handset.

Place the handset into the holder using the cone end of the shower hose.

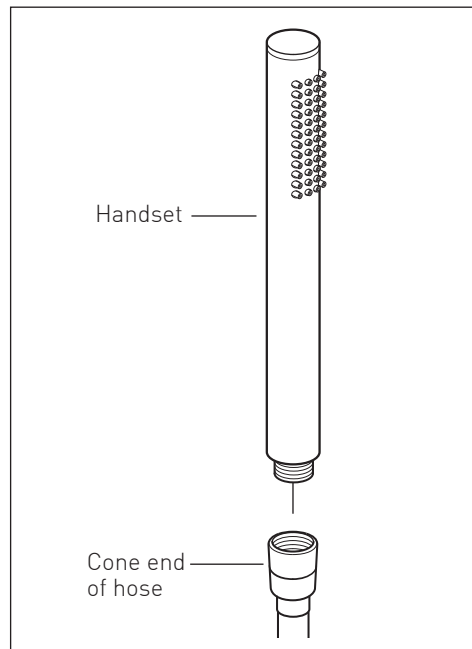

### Outlet hose connection

Make sure there is a rubber washer in the nut end of the shower hose and screw onto the outlet.

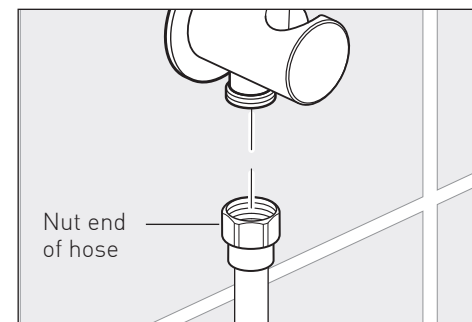

## Cleaning instructions

The coating on this product is finished to the highest standard. Due care needs to be taken to ensure the appearance is retained.

We recommend cleaning all products with a soft damp cloth ONLY and advise strongly against the use of all aggressive/corrosive cleaning products i.e. powders and liquids. If these instructions are not followed, this may invalidate your guarantee in the event of a problem occurring.

## Maintenance

### Flow regulator

If required, a flow regulator can be **inserted into the handset** to conserve water.

Insert the flow regulator make sure that the flow regulator is in the orientation as shown below.

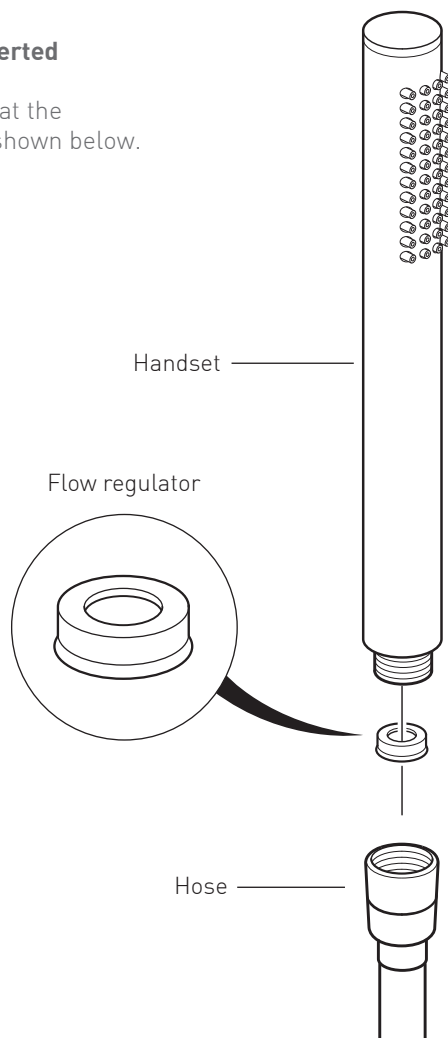

## Guarantee

All VADO products come with a 2 year guarantee as standard. Within this guarantee period, VADO will provide replacement parts and any labour **[SEE NOTE 1]** needed to complete the product repair.

This standard guarantee may be extended by registering your product on our website at: <https://www.vado.com/support/guarantee>.

Once registered, this product will have a 15 year (2 years parts and labour plus 13 years parts only) or a 10 year (2 years parts and labour plus 8 years parts only) guarantee dependant on the finish.

Chrome (CP) = 15 years

Pewter (PEW), Matt Black (MB), Satin Brass (SBR) = 10 years

### Guarantee Conditions

Our products are guaranteed against manufacturing defects from the date of purchase until the expiry of the relevant guarantee period shown above.

The guarantee is only valid if:

- The product has been installed, used and maintained in accordance with VADO's instructions and subjected to normal use only.
- The defect is not due to accident, misuse, neglect, or incorrect/inappropriate repair (other than by VADO or VADO authorised agents) or damage caused by foreign objects or substances.
- The extended guarantee is only available if you have completed the guarantee registration process.

This can be done via the VADO website or via telephone to our Aftersales team.

Registration must be completed within 6 months from the date of purchase. Under the extended guarantee period VADO will, at its option, offer to supply any replacement product (or component part) assessed to be defective **[SEE NOTE 2]**.

- The guarantee (whether standard or extended) is non-transferable to any subsequent owner.
- Mould, Mildew build up, the effects of limescale and corrosion are not covered under this guarantee.
- This guarantee does not cover damage and/or malfunction caused by inappropriate cleaning (please refer to our recommended care guidelines).

All claims under the guarantee should be notified in the first instance to our Aftersales department, contact details below, this must be done no later than the last day of the relevant guarantee period.

All claims must be accompanied by proof of purchase (sales receipt or delivery note) from an official VADO dealer.

The guarantee does not extend to any consequential loss or damage.

After repair or replacement, the relevant guarantee period will be calculated from the original date of purchase.

VADO operates a policy of continuous product development and therefore reserves the right to change the product, packaging and documentation specifications without notice.

In situations where like-for-like replacements are not possible, VADO will endeavour to provide the closest alternative. E&OE.

### NOTES:

**[1]** Labour via our engineer network is only available in the UK. Attendance by a VADO engineer or sub-contract engineer will be under our standard terms and conditions.

**[2]** VADO reserves the right to charge in advance for a product (or replacement part) pending collection and investigation (at VADO expense) to confirm a defect is due to a manufacturing issue. If a defect is found the charge will be refunded or cancelled.

This guarantee is in addition to and does not affect your statutory rights as a consumer.

Tel: 01934 745163 Email: [aftersales@vado.com](mailto:aftersales@vado.com)