

## Guarantee

All VADO and Booth & Co. products come with a 2 year guarantee as standard. Within this guarantee period VADO will provide replacement parts and any labour **[SEE NOTE 1]** needed to complete the product repair.

This standard guarantee may be extended by registering your product to give up to a 15 year guarantee period. Once registered:

Individual by VADO and Booth & Co. products have a 15 year guarantee (2 years parts plus 13 years parts only) **[SEE NOTE 2]**.

### Guarantee conditions

Our products are guaranteed against manufacturing defects from the date of purchase until the expiry of the relevant guarantee period shown above.

The guarantee is only valid if:

- The product has been installed, used and maintained in accordance with VADO's instructions and subjected to normal use only.
- The defect is not due to use of an unsuitable or inadequate water or power supply.
- The defect is not due to accident, misuse, neglect or incorrect/inappropriate repair (other than by VADO or VADO authorised agents) or damage caused by foreign objects or substances.
- The extended guarantee is only available if you have completed the Guarantee Registration Process.

This can be done via the VADO website or via phone to our aftersales team. Registration must be completed within 6 months from date of purchase.

Under the extended guarantee period VADO will, at its option, offer to supply any replacement product (or component part) assessed to be defective **[SEE NOTE 3]**.

The guarantee (whether standard or extended) is non-transferable to any subsequent owner. All claims under the guarantee should be notified in the first instance to our Aftersales department, contact details below, this must be done no later than the last day of the relevant guarantee period. All claims must be accompanied by proof of purchase (sales receipt or delivery note) from an official VADO dealer.

The guarantee does not extend to any consequential loss or damage.

After repair or replacement, the relevant guarantee period will be calculated from the original date of purchase.

VADO operates a policy of continuous product development and therefore reserves the right to change the product, packaging and documentation specifications without notice.

### NOTES:

**[1]** Labour via our engineer network is only available in the UK. Attendance by a VADO engineer or sub-contract engineer will be under our standard terms and conditions.

**[2]** VADO spare parts and shower hoses are under a parts only guarantee.

**[3]** VADO reserves the right to charge in advance for a product (or replacement part) pending collection and investigation (at VADO expense) to confirm a defect is due to a manufacturing issue.

If a defect is found the charge will be refunded or cancelled. This guarantee is in addition to and does not affect your statutory rights as a consumer.

Tel: 01934 745163

Email: [aftersalescare@vado.com](mailto:aftersalescare@vado.com)

KEEP FOR  
FUTURE REFERENCE



AXBRIDGE

SHOWER BATH VALVE  
WITH RISER  
USER GUIDE

BOOTH & Co.  
ENGLAND

## Welcome to Booth & Co.

Expertly designed in our home town of Cheddar, Somerset, each Booth & Co. product is as time-honoured on the outside as it is pioneering within.

Hand-crafted to exude a distinct, timeless sophistication, this product has passed through stringent quality assurance processes and demanding lifecycle mechanical testing to ensure an unrivalled quality.

Our leading 15 year guarantee certifies excellence within every detail.

Part of the VADO family, Booth & Co. retains the same outstanding customer service and large scale development support that earned VADO a globally trusted reputation. For any technical or operation queries, please contact our experienced Aftersales team on 01934 745 163.

Indulge in luxury as it should be.

VADO  
Wedmore Road, Cheddar,  
Somerset, England BS27 3EB  
tel 01934 744466  
fax 01934 744345  
www.vado.com  
sales@vado.com

2

## Commissioning

Rotate the spline of the thermostatic cartridge clockwise to decrease and anti-clockwise to increase the temperature until 38°C is achieved at the outlet **(fig 3)**.

**Note:** the sensing part of the thermometer probe must be fully submerged in the water that is to be tested.

Carefully replace the spacer ring, shroud and temperature handle with the temperature indicator located at 12 o'clock without turning the spline of the thermostatic cartridge.

Screw the temperature handle in place using the washers and screw, replace the screw cover.

Ensure the water temperature does not exceed 46°C when turned entirely anti-clockwise.

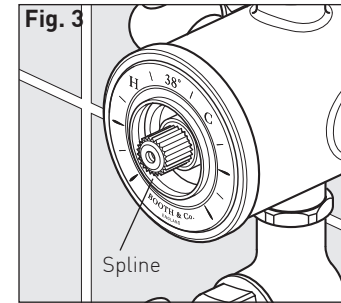

## Commissioning

The valve has been factory set under balanced pressures and hot supply at 65°C. When your specific operating conditions are significantly different from the above, the temperature of the delivered water may vary from the setting.

When the difference is too great, you can adjust the calibration of the valve to suit individual requirements of the installation.

**Note:** mixed water temperature at the terminal fitting should not exceed 46°C.

With the temperature handle fitted and the temperature indicator located at 12 o'clock, check the temperature of the water being delivered from the outlet with a thermometer.

**Note:** temperature readings should be taken at normal flow rate after allowing the system to stabilize.

If the temperature is not 38°C proceed to commission the valve as follows.

Prise out the ceramic screw cover, remove the screw and washers and pull off the handle, shroud and spacer ring (**fig 1**).

Ensure the step on the stop ring is as pictured (**fig 2**).

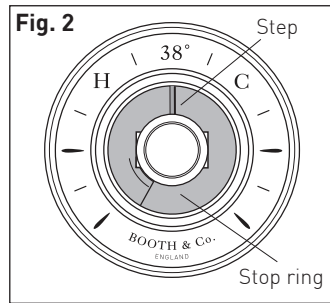
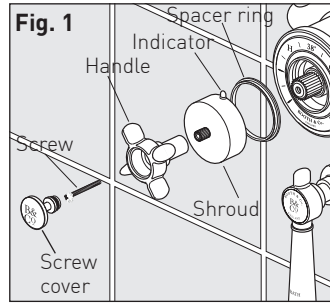

## Cleaning instructions:

The electroplating on this product is finished to the highest standard. Due care needs to be taken to ensure the appearance is retained.

We recommend cleaning all products with a soft damp cloth **ONLY** and advise strongly against the use of all aggressive/ corrosive cleaning products i.e. powders and liquids. If these instructions are not followed, this may invalidate your guarantee in the event of a problem occurring.

## Operation - temperature

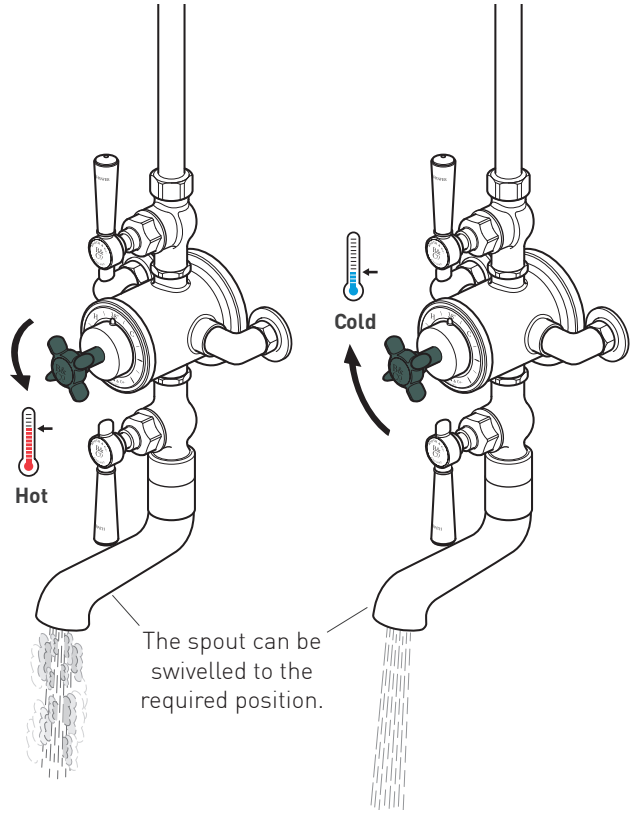

Turning the temperature handle anti-clockwise will increase the flow of hot water.

Turning the temperature handle clockwise will increase the flow of cold water.

## Maintenance

6. Clean the cartridge filters by rinsing them under running water to remove any debris.

7. If there is limescale deposits then it is recommended to immerse the cartridge for a few minutes in 50% white vinegar + 50% hot water, brush the filters gently and then rinse under running water to clean all particles. If this is not effective, a replacement cartridge should be fitted.

8. Before reassembling the cartridge, clean its housing with a wet cloth and grease the O-rings using a suitable silicone grease. Insert the thermostatic cartridge into the body aligning the slot in the body with the grub screw (fig 4).

9. Screw the securing nut on and tighten using a box spanner, careful not to overtighten.

10. Replace the temperature stop ring on the cartridge with the step located at 12 o'clock (fig 5).

11. Turn the water supply on.

12. Check the water temperature to ensure correct commissioning. See previous section.

13. Replace the ceramic/chrome temperature ring, spacer ring and shroud with the temperature indicator located at 12 o'clock without turning the spline of the thermostatic cartridge. Screw the temperature handle in place using the washers and screw, replace the screw cover.

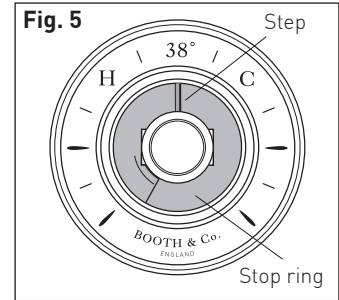
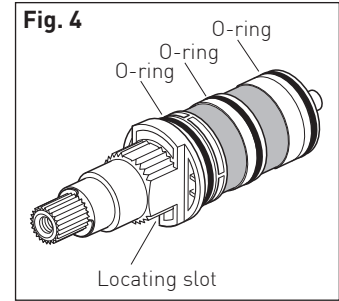

## Maintenance

We advise that the below is carried out annually as failure to do so may result in invalidation of warranty. Shut off the water supply to both hot and cold inlets, before commencing any maintenance work below.

### Thermostatic cartridge

To clean the filters, you must first remove the cartridge from the housing.

#### Removing the Cartridge

**1.** Shut off the water supply to both inlets at the isolating valves. Ensure the thermostatic valve has been successfully isolated.

**2.** Using a suitably flat tool remove the screw cover, unscrew and remove the temperature handle and pull off the metallic shroud housing and spacer ring (fig 1).

**3.** Using pliers if required gently remove temperature stop ring (essential) (fig 2). Remove the ceramic/chrome temperature ring allowing access to the valve (fig 2).

**4.** Turn shower on to check isolation, please ensure that your body/hands are not under the flow of water as there is a potential for delivery of hot water.

**5.** Using a 32mm box spanner unscrew and remove the valve securing nut then carefully pull out the thermostatic cartridge (fig 3).

**Note:** Ensure care is taken as a small amount of residual water may escape when removing the cartridge.

**Note:** Ensure care is taken as a small amount of residual water may escape when removing the cartridge.

8

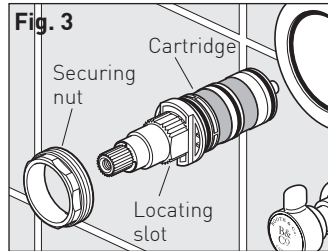
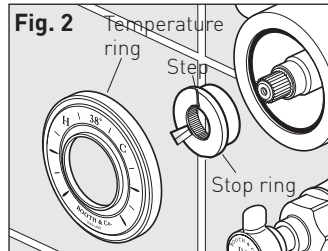
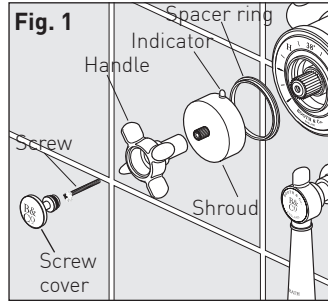

## Operation - flow

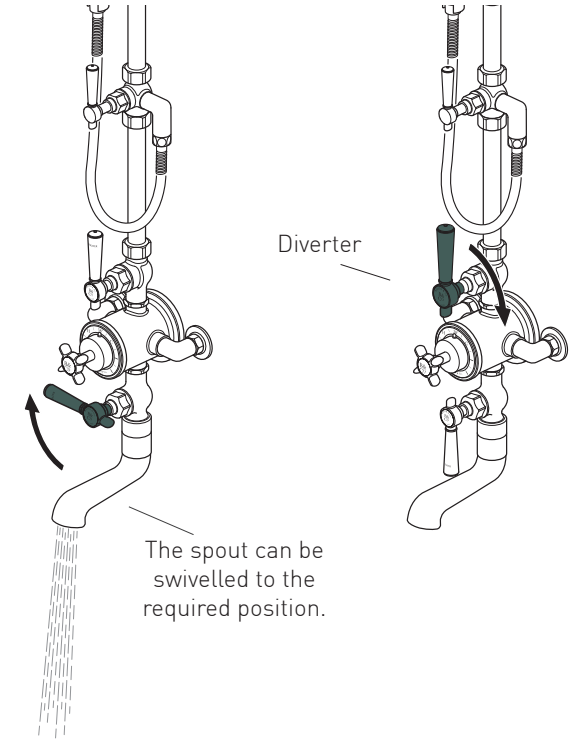

Turning the handle clockwise will divert the flow of water to the spout.

Turning the handle clockwise will divert the flow of water to the Handset/shower head. Depending on the position of the diverter (see page 6).

5

## Operation - diverter

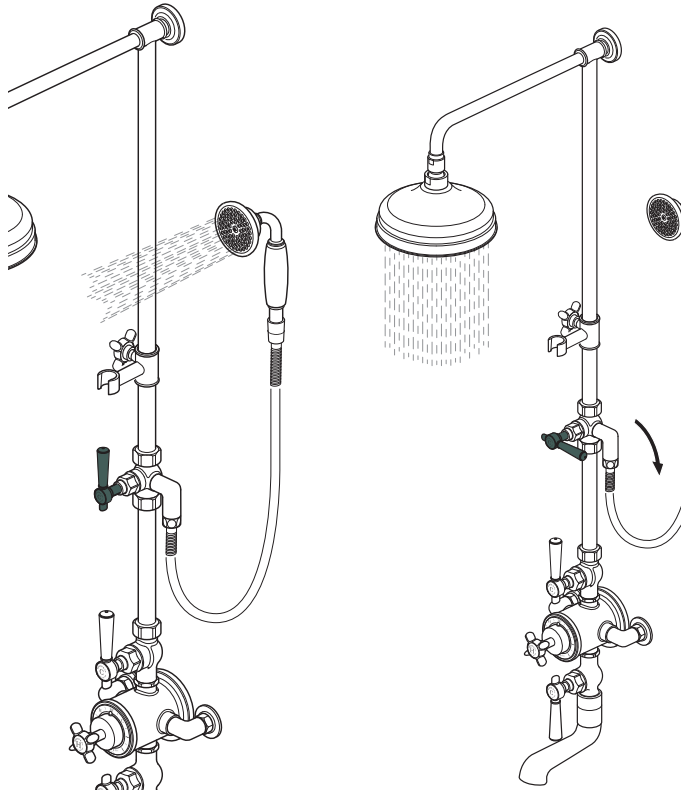

Turning the handle to the 12 o'clock position will divert the flow of water to the handset.

6

## Operation - handset holder

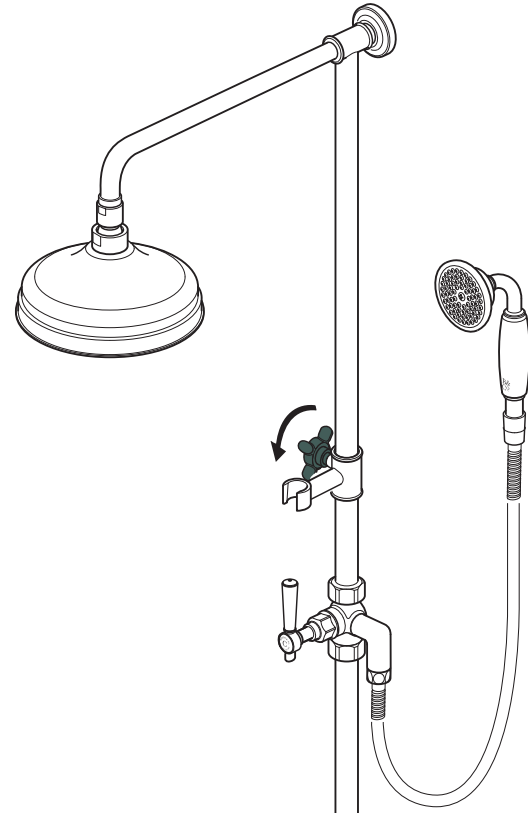

Release the handle on the holder, slide the holder to the required position and retighten. Place the handset into the holder.

7