

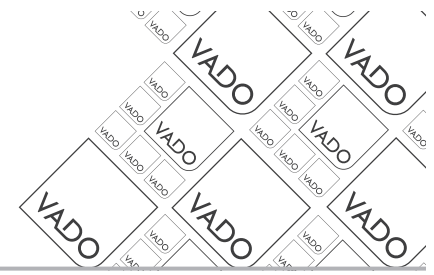

where inspiration flows

CAMEO



Installation Guide
Vanity Unit

This instruction booklet covers these models:

CAM-F500, CAM-F600, CAM-F800
(All finish options)

CAM-F500
CAM-F600
CAM-F800

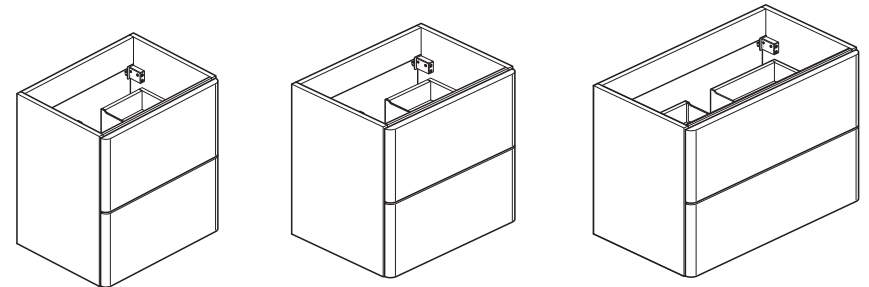

Vado
Wedmore Road, Cheddar, Somerset, England BS27 3EB
tel 01934 744466. fax 01934 744345
aftersales@vado.com
www.vado.com



Important - Please Read

VADO reserves the right to make technical improvements and enhance the appearance of the products included in this instruction manual.

Please read these instructions carefully before starting the installation and keep for future reference.

Remove all packaging and check the product for missing parts or damage before starting installation.

Any unadvised alterations made to this product will invalidate the guarantee.

Please take great care when installing this product to avoid damage to its surface.

This installation guide details fitting to a solid wall. Ensure the wall can take weight of units detailed above.

Please note that some units are heavy. Take care when lifting, and follow health and safety guidelines. It is recommended that 2 people carry out the installation of larger basin/ vanity units over 30Kgs gross weight.

Check for any hidden pipes or electrical cables before drilling holes in the wall.

When deciding where to install the vanity consider the potential overhang.

Important - Preparation

Recommended install heights We recommend installing these vanities onto solid walls. For installations onto non solid walls, consult the diagram below.

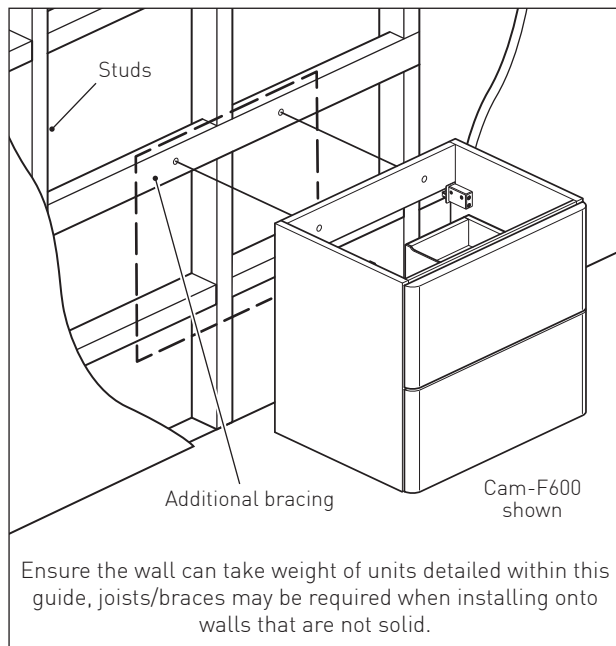
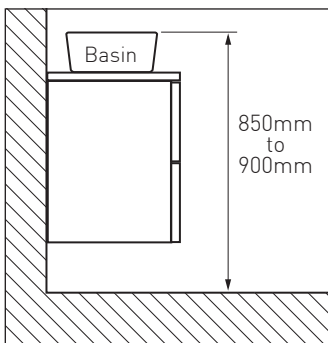
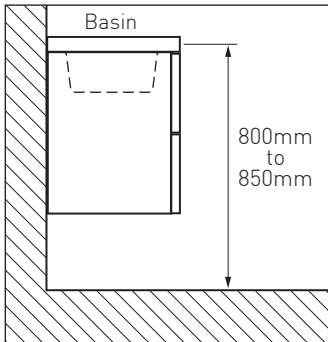

Contents of Packaging

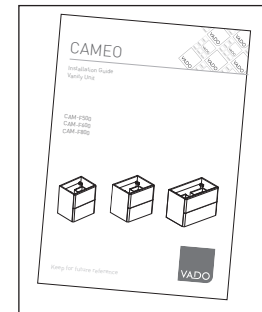

Installation guide

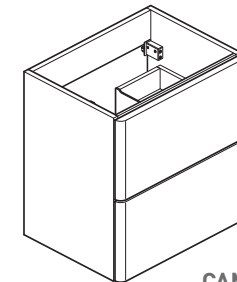

CAM-F500

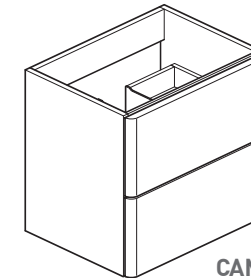

CAM-F600

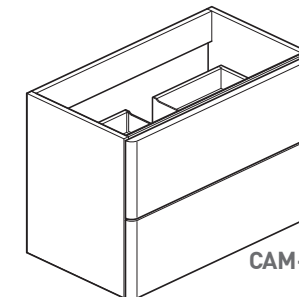

CAM-F800

HANDLE OPTIONS



CAM-HAN5 handle x 2
plus screws



CAM-HAN6 handle x 2
plus screws

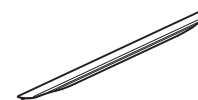

CAM-HAN8 handle x 2
plus screws

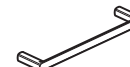

CAM-HANB handle x 2
plus screws



CAM-HANK handle x 2
plus screws

FIXING KIT

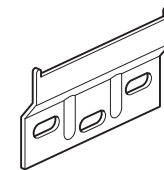

Wall Brackets x 2



Wall plugs x 10



Screws x 10



Washer x 4



Cover sticker x 4

Dimensions - CAM-F500 & CAM-F600

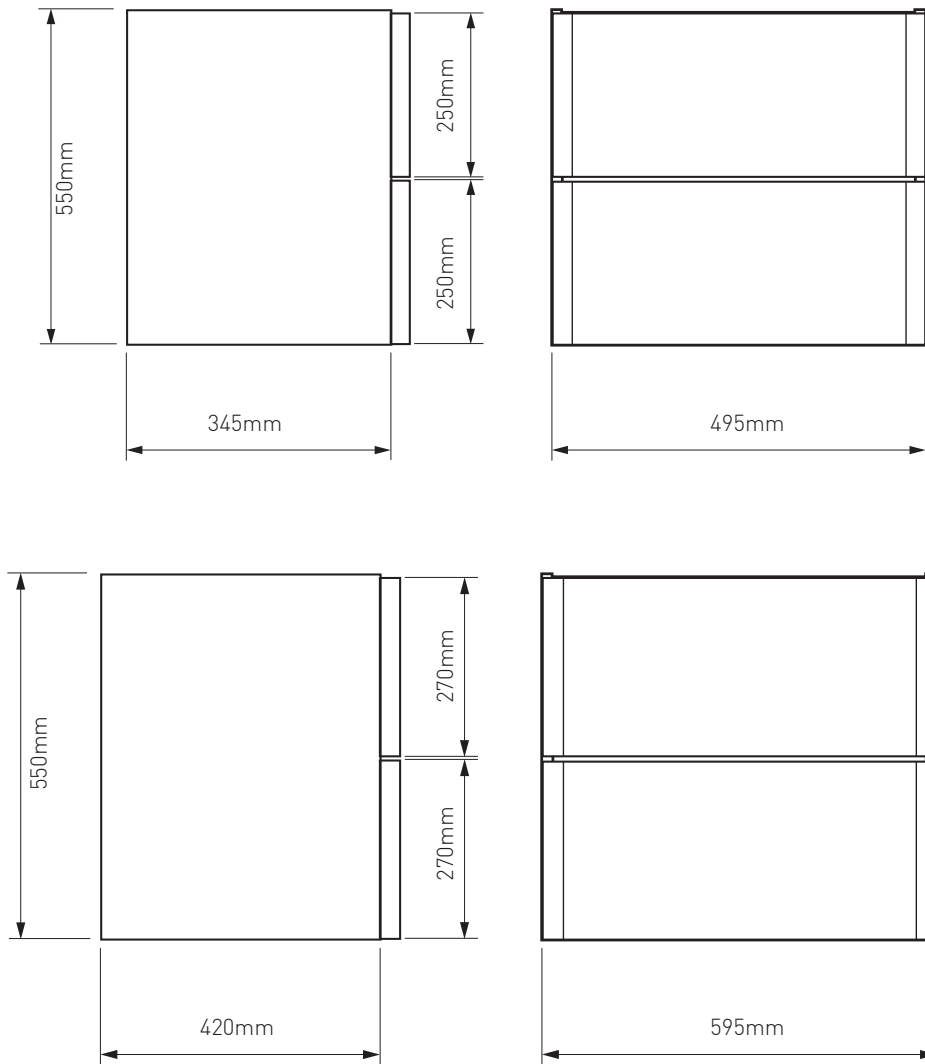

Dimensions - CAM-F800

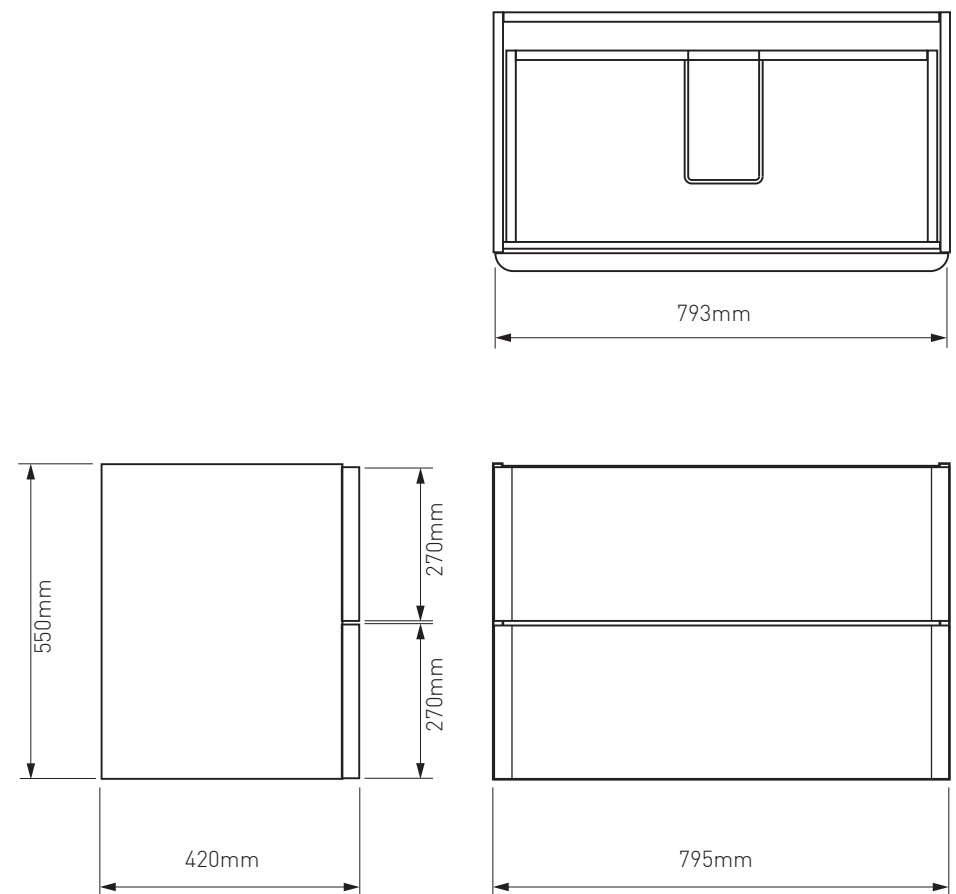

Installation

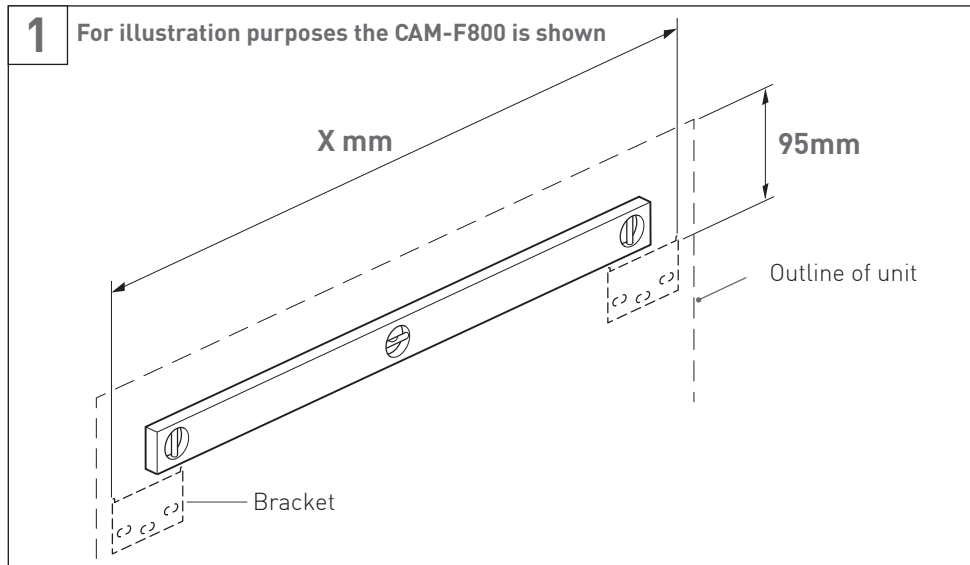

Decide on the position and height of the unit. The recommended basin height is between 800 and 900mm from floor to top of basin. Mark the bracket fixing holes onto the wall. **NOTE:** The dimensions are for the maximum width over the brackets.

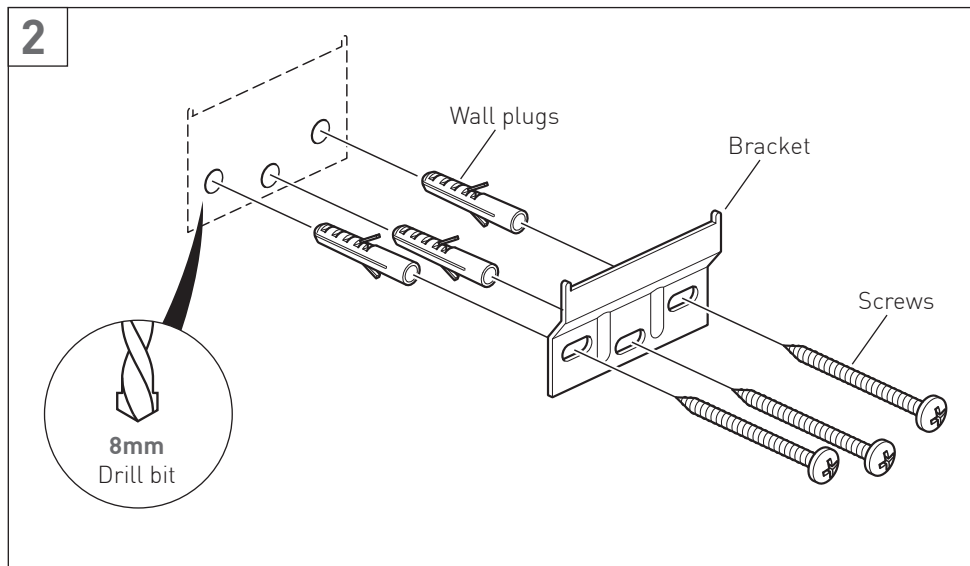

Drill \varnothing 8mm holes, insert the wall plugs and screw on the brackets.
NOTE: If the vanity unit and/or basin are not fitted level this may prevent the basin from draining correctly.

Installation

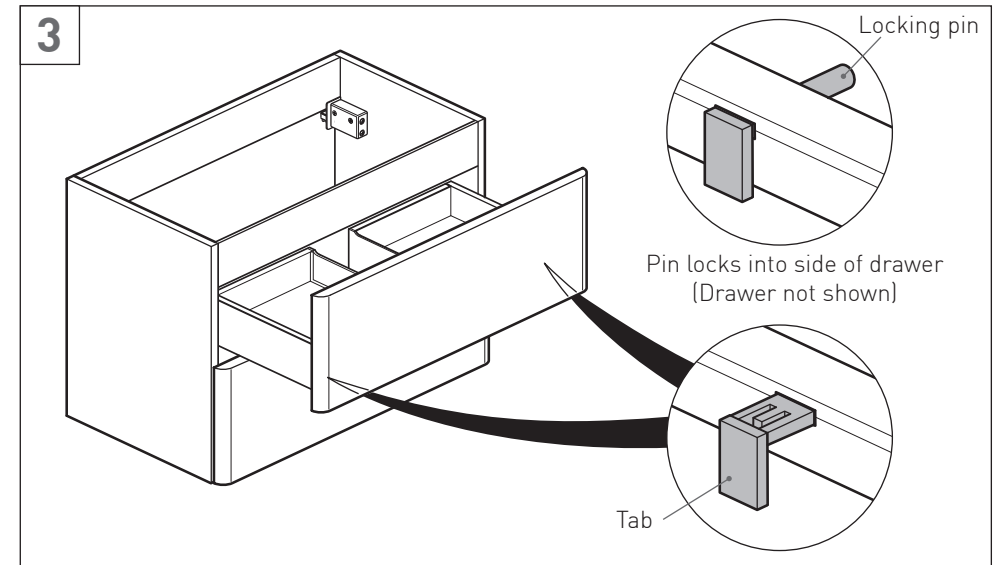

Remove the drawers prior to fitting the unit on to the wall. Pull out a drawer so it's fully extended. On the underside of the runners, push each tab towards the centre of the unit until you hear a click.

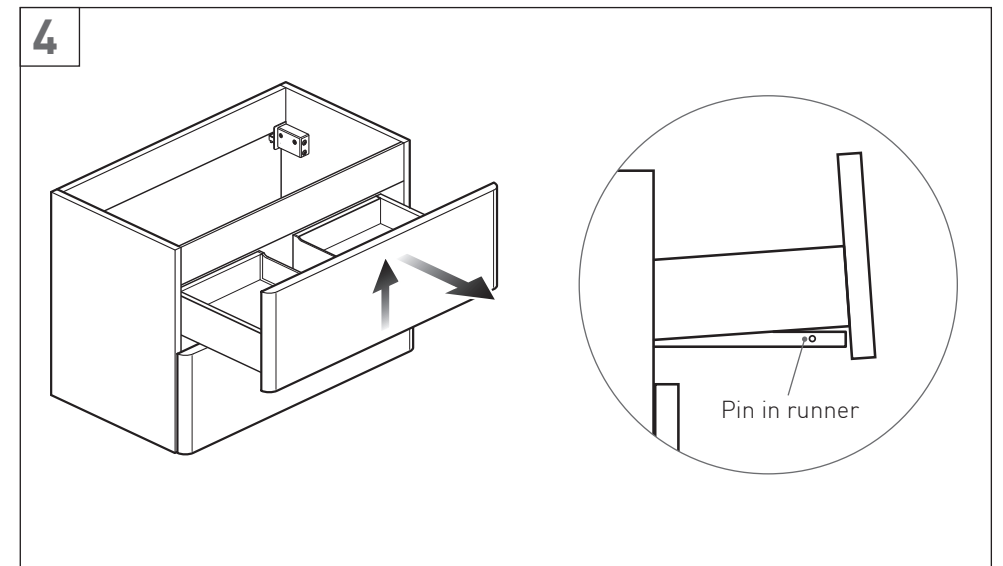

Gently lift the drawer forward to disengage it from the runner and remove from the cabinet. Repeat for the other drawer.
NOTE: Cover the drawer runners to prevent debris from getting into the mechanism.

Installation

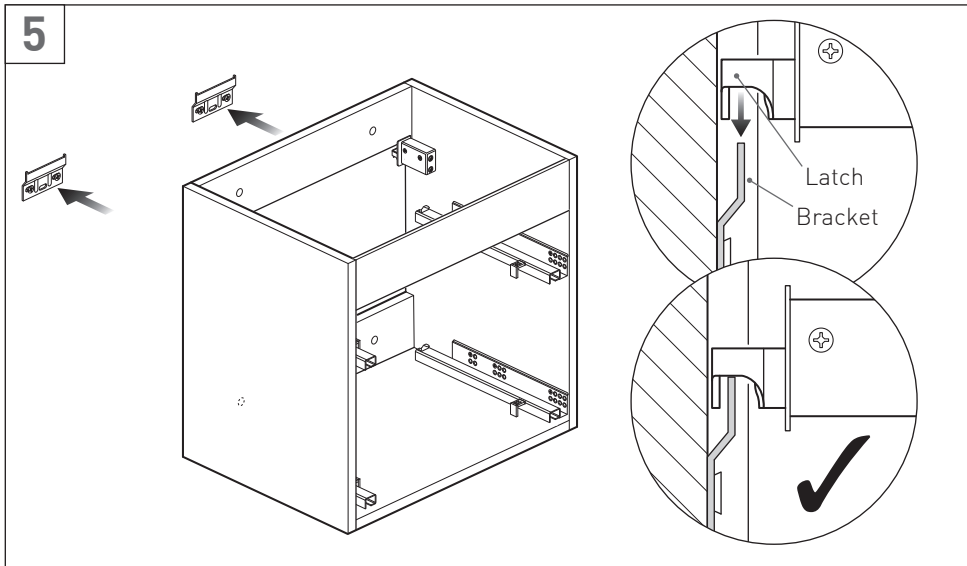

With two people lift the unit over and onto the brackets, make sure that both latches are over the brackets before releasing the unit.

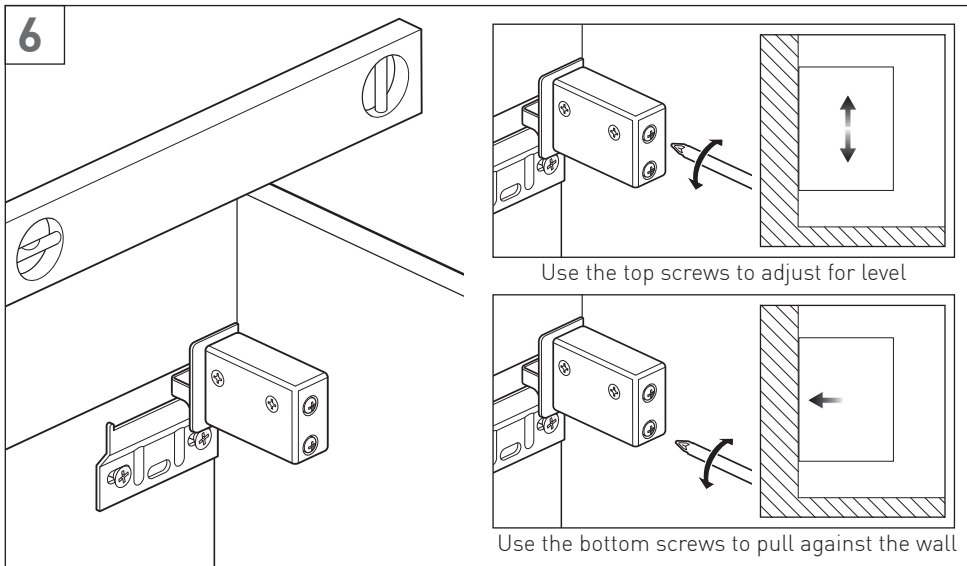

Check the unit is level. If leveling is required, use the top screw on both sides to lower or lift the unit.

Once level, use the bottom screws on the hangers to clamp the unit to the wall.

Installation - additional fixing method

If required, the vanities can also be fixed in the positions shown below.

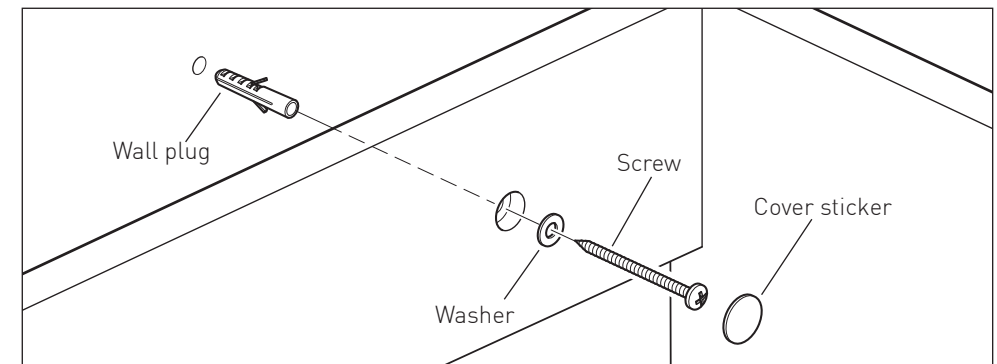
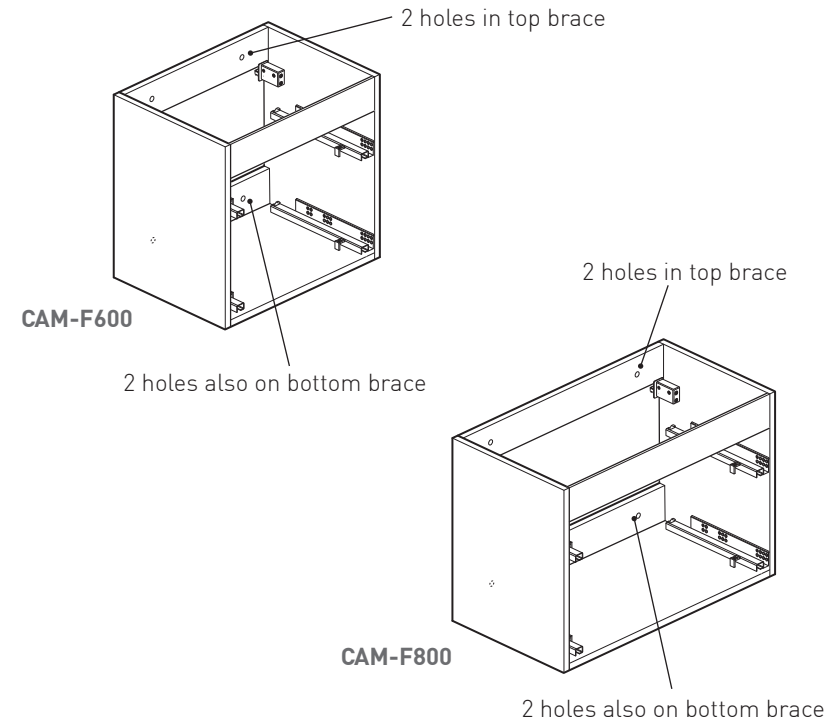

Solid Walls - Drill \varnothing 8mm holes into the wall through the holes in the braces, insert a wall plug, washer and screw through each hole. Place the adhesive sticker over the hole.

Partition walls - Screw directly into the studs without using the wall plugs.

Installation - worktop installation

Drill any required holes in the worktop before installing on the vanity.

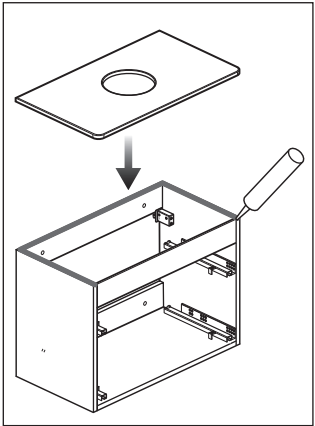

Apply a non-acidic silicone along the top edge of the unit and carefully position the countertop ensuring that it is flush with the sides of the vanity unit.

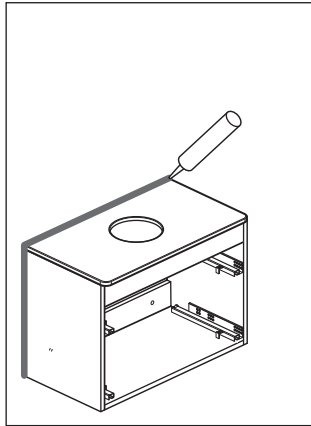

Apply a bead of silicone along the back and sides of the countertop. Allow to set fully.

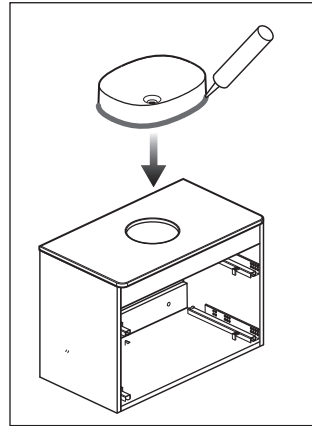

Fix basin by applying silicone on the outer edge of the basin.

Installation - basin installation

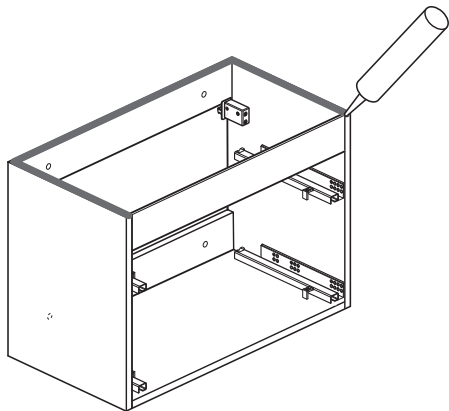

Apply silicone non-acidic to the side and front edges of the unit. Carefully position the basin down onto the unit ensuring that it is centrally positioned and flush at the back.

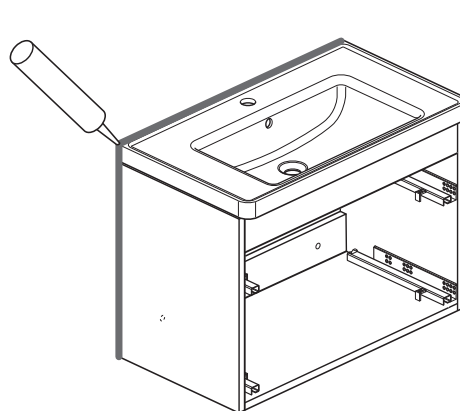

Apply a bead of silicone along the back and sides of the basin. Allow to set fully.

Installation - drawers

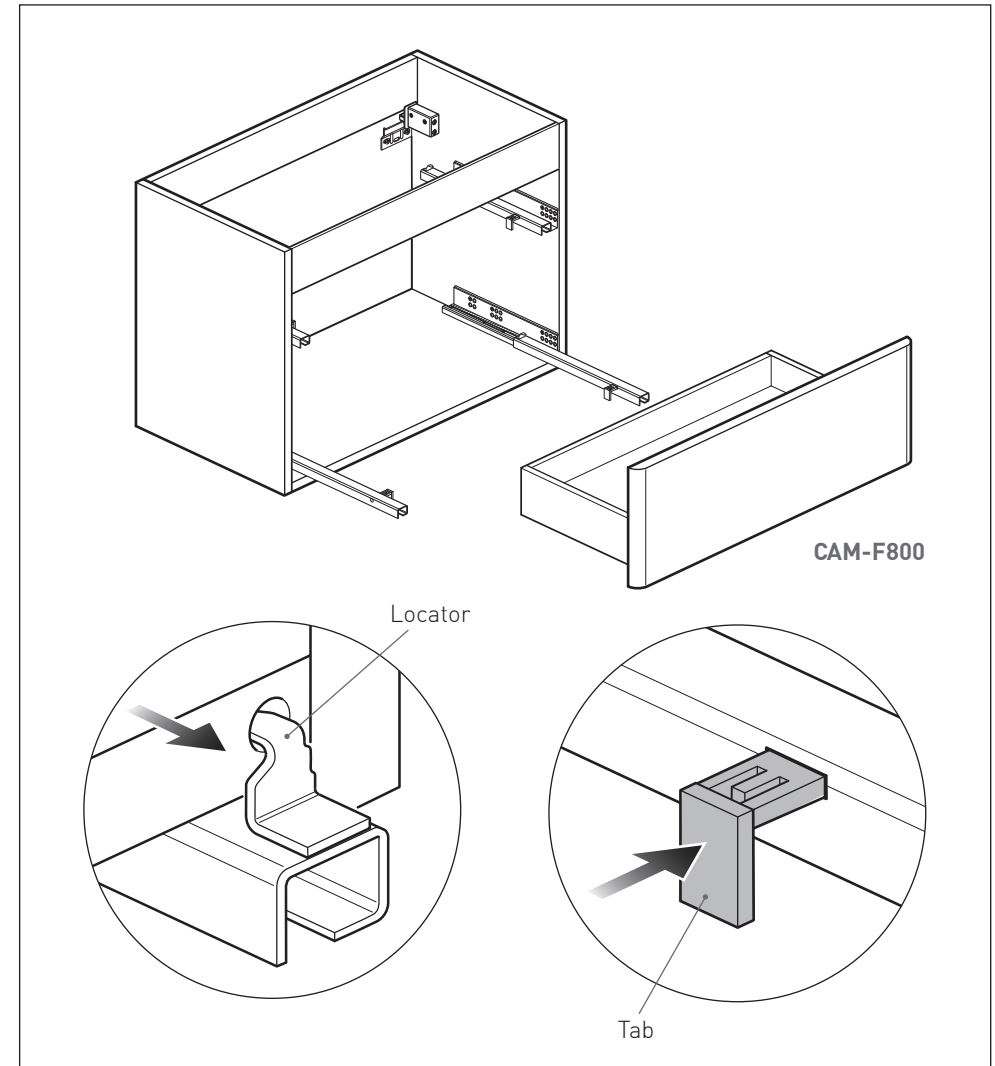

Place the drawer onto the bottom extended runners. Slide the drawer back until the locator is in the hole on the back of the drawer. Push the tabs on the underneath back into the runners (until you hear a click) to secure the drawers.

Repeat the same procedure for the top drawer.

To level the drawers, use the screws on either side of the runners.

Installation - door handle

CAM-HAN5, CAM-HAN6 and CAM-HAN8 handles

Line up the handle on the drawer making sure the edges are flush with the top of the drawer, mark the holes.

Drill pilot holes and screw on the handle using the screws provided.

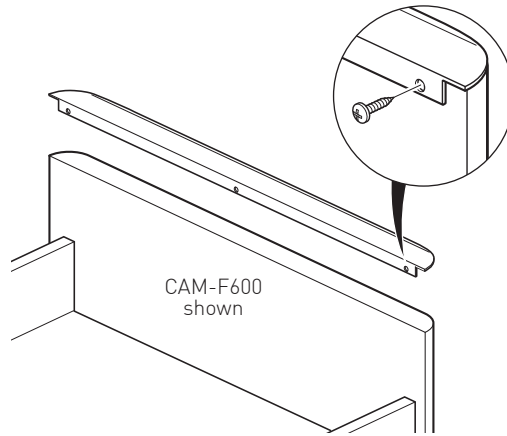

CAM-HANK handle

Find the centre of the draw and drill a starter hole through the front face using 2.5mm drill bit. Drill again using a 5mm drill bit. Attach the handle using the longer (40mm) screw provided.

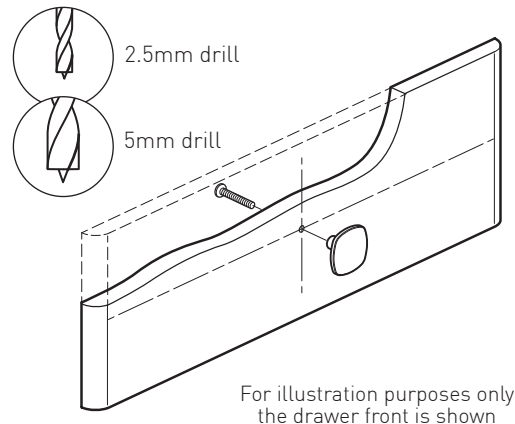

Note: Make sure your drill is set at exactly 90 degrees to the door's surface.

CAM-HANB handle

Find the centre of the draw and line up the handle horizontally, mark the screw points and drill a starter holes through each mark on the front face using 2.5mm drill bit. Drill again using a 5mm drill bit.

Attach the handle using the longer (40mm) screw provided.

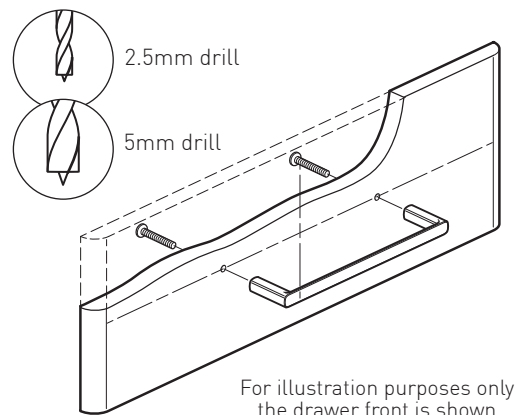

Note: Make sure your drill is set at exactly 90 degrees to the door's surface.

Cleaning Instructions

The coating on this product is finished to the highest standard. Due care needs to be taken to ensure the appearance is retained.

We recommend cleaning all products with a soft damp cloth ONLY and advise strongly against the use of all aggressive/corrosive cleaning products i.e. powders and liquids. If these instructions are not followed, this may invalidate your guarantee in the event of a problem occurring.

⚠ Note: Bathroom furniture will deteriorate through extended exposure to elevated levels of condensation. To mitigate this, it is imperative that bathrooms are equipped with an appropriate ventilation system, such as an extractor fan.

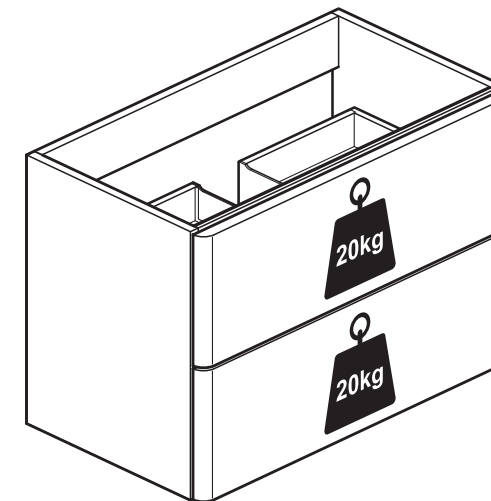

⚠ Each draw has a weight limit of 20kg.

Notes:

Guarantee

This VADO vanity unit comes with a 2 year guarantee as standard. Within this guarantee period, VADO will provide replacement parts.

This standard guarantee may be extended by registering your product on our website at: <https://www.vado.com/support/guarantee>. Once registered this vanity unit will have a 6 year guarantee.

Guarantee Conditions

Our products are guaranteed against manufacturing defects from the date of purchase until the expiry of the relevant guarantee period shown above.

The guarantee is only valid if:

- The product has been installed, used and maintained in accordance with VADO's instructions and subjected to normal use only.
- The defect is not due to accident, misuse, neglect, or incorrect/inappropriate repair (other than by VADO or VADO authorised agents) or damage caused by foreign objects or substances.
- The extended guarantee is only available if you have completed the guarantee registration process.

This can be done via the VADO website or via telephone to our Aftersales team.

Registration must be completed within 6 months from the date of purchase. Under the extended guarantee period VADO will, at its option, offer to supply any replacement product (or component part) assessed to be defective **[SEE NOTE 1]**.

- The guarantee (whether standard or extended) is non-transferable to any subsequent owner.
- Mould, Mildew build up, the effects of limescale and corrosion are not covered under this guarantee.
- This guarantee does not cover damage and/or malfunction caused by inappropriate cleaning (please refer to our recommended care and maintenance guidelines).
- Damage to VADO furniture caused by standing water or inadequate room ventilation is not covered under this guarantee.

All claims under the guarantee should be notified in the first instance to our Aftersales department, contact details below, this must be done no later than the last day of the relevant guarantee period.

All claims must be accompanied by proof of purchase (sales receipt or delivery note) from an official VADO dealer.

The guarantee does not extend to any consequential loss or damage.

After repair or replacement, the relevant guarantee period will be calculated from the original date of purchase.

VADO operates a policy of continuous product development and therefore reserves the right to change the product, packaging and documentation specifications without notice.

In situations where like-for-like replacements are not possible, VADO will endeavour to provide the closest alternative. E&OE.

NOTES:

[1] VADO reserves the right to charge in advance for a product (or replacement part) pending collection and investigation (at VADO expense) to confirm a defect is due to a manufacturing issue. If a defect is found the charge will be refunded or cancelled.

This guarantee is in addition to and does not affect your statutory rights as a consumer.

Tel: 01934 745163

Email: aftersales@vado.com